

Dynamic Decision Behavior and Optimal Guidance through Information Services: Models and Experiments

Dirk Helbing^{1,2,3}

¹ Institute for Economics and Traffic, Faculty of Traffic Sciences “Friedrich List”, Dresden University of Technology, D-01062 Dresden, Germany

² Collegium Budapest – Institute for Advanced Study, Szentháromság u. 2, H-1014 Budapest, Hungary

³ CCM—Centro de Ciências Matemáticas, Universidade da Madeira, Campus Universitário da Penteada, Pt-9000-390 Funchal, Madeira, Portugal

Abstract. In this contribution, dynamical models for decision making with and without temporal constraints are developed and applied to opinion formation, migration, game theory, the self-organization of behavioral conventions, etc. These models take into account the non-transitive and probabilistic aspects of decisions, i.e. they reflect the observation that individuals do not always take the decision with the highest utility or payoff. We will also discuss issues like the freedom of decision making, the red-bus-blue-bus problem, and effects of pair interactions such as the transition from individual to mass behavior.

In the second part, the theory is compared with recent results of experimental games relevant to the route choice behavior of drivers. The adaptivity (“group intelligence”) with respect to changing environmental conditions and unreliable information is very astonishing. Nevertheless, we find an intermittent dynamical reaction to aggregate information similar to volatility clustering in stock market data, which leads to considerable losses in the average payoffs. It turns out that the decision behavior is not just driven by the potential gains in payoffs. To understand these findings, one has to consider reinforcement learning, which can also explain the empirically observed emergence of individual response patterns. Our results are highly significant for predicting decision behavior and reaching the optimal distribution of behaviors by means of decision support systems. These results are practically relevant for any information service provider.

1 Introduction

Decision theory is a central field in the socio-economic sciences, as decisions determine a major part of human interactions. Therefore, decision theory is essential for the deductive derivation and microscopic understanding of the macroscopic phenomena observed in society and economics, such as

- social exchange or economic markets,
- the formation of groups, companies, institutions, or settlements,
- the dynamics of stock markets, business cycles, and other instability phenomena.

One may hope that, once the *elementary interactions* among individuals are understood by means of experimental and numerical studies, all regular phenomena should in principle be derivable from these interaction laws. This optimistic vision is motivated by the great success in the derivation of the structure, dynamic behavior, and properties of matter from elementary physical interactions. Scientists would like to understand the spatio-temporal patterns in socio-economic systems in a similar way.

This paper is an attempt to develop a consistent theoretical approach to human decision behavior (certainly an incomplete one). In Secs. 2.2 to 2.5, we will discuss how decisions come about, why they are so time-consuming, and what happens, if there is not enough time to complete the decision-making process. We also touch the topic of the freedom of will. Based on this, we will develop a quantitative theory for the probability of decision changes. This will take into account situations of incomplete information and limited processing capacities, thereby generalizing the concept of *homo economicus*. As a consequence, our theory implies a transitive preference scale only in special cases. In Secs. 2.9 to 3.6, we also discuss the effects of non-linearities due to individual pair interactions. In this way, we can understand fashion cycles and chaotic decision dynamics, the self-organization of behavioral conventions, polarization phenomena, and transitions from individual to mass behavior. These phenomena can be understood by means of game-dynamical equations, which are a special case of the derived Boltzmann equations for decision changes. Other special cases are the logistic equation, the gravity model, or social force models.

Our evaluation results of a generalized day-to-day route choice experiment show (when we average over the behavior of all test persons) a non-transitive behavior, because the empirical decision probability is not monotonically increasing with the payoff or expected payoff gain. This can be incorporated into the previously developed decision theories, if learning behavior is taken into account (see Sec. 5), which has been quantified from the experimental data (see Sec. 4).

It turns out that the decision dynamics is volatile and related with considerable losses in the average payoffs. We find, however, that already small differences in the way of information presentation can reach surprisingly large improvements. By far the best performance in terms of average and individual payoffs can be reached by user-specific recommendations. Taking into account the empirical compliance rates of the individuals, it is possible to solve the problem of traffic forecasts which are in harmony with the driver reactions to them. These findings are of general importance for information service providers and for the efficient distribution of scarce resources such as road capacities, time, space, money, energy, goods, or our natural environment. Nevertheless, the proposed method does not facilitate to manipulate the individuals by biased recommendations, as the compliance rate goes down accordingly: Our test persons followed the recommendations just to the degree they were useful for them to reach the user equilibrium.

2 Modelling Dynamic Decision Behavior

The following sections are trying to shed some new light on several old questions in the field of decision theory. Nowadays, there exists a variety of different models for the description of particular aspects of decision behavior, which have been developed by psychologists, social scientists, economists, and behavioral biologists in parallel. However, until today there is no consensus about a general and unified description of decision behavior. Therefore, the particular challenge will be the formulation of a consistent approach, which allows us to cover many aspects as special cases of one single theory.

2.1 Questioning Transitive Decisions and Homo Economicus

Human decision making has been subject to scientific research for a long time. In the beginning, there was a considerable progress in the interpretation and quantitative description of decision making. It was, in fact, one of the few areas in the social sciences where mathematical laws were formulated with some success. We mention the postulate that decisions are *transitive*, implying that there is a one-dimensional preference scale. In other words: If we prefer decision A to B and B to C , we will favour A compared to C . This idea was further developed with the concept of the *homo economicus*, according to which individuals would behave perfectly rational based on immediate and complete information, i.e. one would always choose—in a deterministic and predictable way—the alternative with the highest utility or payoff. Great economic theories are based on this concept, but it is more and more questioned:

- First of all, decisions are hardly predictable. This can have several reasons: *Deterministic chaos* (like *intermittency*, see Sec. 4.3), *incomplete information* (i.e., “hidden variables”), or probabilistic factors such as *fluctuations*.
- Second of all, individuals have to struggle with *imperfect information* due to *finite memory* and *limited processing capabilities*.
- Apart from this, there are *delays in information gathering*, which can cause instabilities as in other systems with delayed reaction (see Sec. 4.3 and Ref. [1]).
- Based on behavioral studies, scientists have also recognized that *emotions* affect the outcome of decisions (cf. the studies in *behavioral economics* [2] and *behavioral finance* [3]). For example, the decision distribution regarding emotional issues tends to be *polarized*, i.e. *bi-modal* rather than Gaussian, in contrast to unemotional or boring issues.
- The *El Farol bar problem* [4] and the *minority game* [5–7] even show that, in certain situations, there exists no rational (optimal deterministic) strategy. If all individuals had perfect information and would do the same, everyone would lose.

The facts known today call for a new theoretical approach for *boundedly rational agents* [4], but the concept of the *homo economicus* is so wide-spread, that new

approaches have hard times to win through. In the beginning, this concept was a very useful tool as it allowed scientists to carry out analytical calculations and to develop economic theories. For a certain time period, this actually justified the simplifications made. Nowadays, however, classical economists are afraid of a break-down of their theories, if they would permit a questioning of the underlying assumptions. In fact, nobody knows exactly which chapters of economy would have to be rewritten, to what extent, and how it would have to be done, if these assumptions were relaxed. However, today computer simulations can complement analytical calculations where the complexity of the model is too high for obtaining rigorous results. This approach has been enormously powerful in physics and other natural sciences. Of course, computational results must always be checked for consistency, plausibility, and tested against empirical data. This requires a particular experience in modelling, programming, and data analysis, which should be a substantial part of the training of young scientists.

2.2 Probabilistic Decision Theories

Empirical studies clearly support that decision behavior is rather probabilistic than deterministic. In many cases, the relative frequency $p(i)$ of usage of a strategy i was found to be proportional to the number $N(i) \geq 0$ of times it was successful (which implies a *trial and error* behavior, at least in the beginning). In mathematical terms, this *law of relative effect* [8–10] reads

$$p(i) = \frac{N(i)}{\sum_{i'} N(i')} . \quad (1)$$

Without loss of generality, for any parameter T we can introduce a function

$$U(i) = T \ln N(i) \quad (2)$$

such that

$$p(i) = \frac{e^{U(i)/T}}{\sum_{i'} e^{U(i')/T}} . \quad (3)$$

The function $U(i)$ is often called *utility function*. It reflects some preference scale and the roughly logarithmic scaling of sensory stimuli, known as *Weber's* or *Fechner's law* [11]. The relation (3) is called the *multinomial logit model* [12,13]. It is perhaps the most prominent example of probabilistic decision models, but there are several other ones [13,14].

The *multinomial logit model* can be also derived in different ways. Notably enough, it resembles the *canonical distribution* of energy levels $E(i) = -k_B U(i)$ in physics [15,16], which can be obtained by *entropy maximization* under the constraint that the average energy $k_B T$ is given [17–19]. The parameter k_B is the Boltzmann constant, and T has the meaning of the *temperature*. Therefore, the parameter T in formula (3) is sometimes called the “*social temperature*” (a more precise interpretation of which is given later on). The parameter T determines the sensitivity to variations of $U(i)$, specifically the sensitivity of the

decision behavior on the variation of the utility. High values of T imply uniformly distributed decisions (an equi-distribution), while the limiting case $T = 0$ means that only the alternative(s) with the highest utility $U(i)$ is (are) chosen. (In non-degenerate cases, this corresponds to deterministic decision behavior.)

In the classical derivation of the multinomial logit model [12], T is a measure for the *uncertainty of information*. This derivation assumes that, due to limited information, $U(j)$ would only reflect the known part of the utility, while $\epsilon(j)$ describes the unknown, stochastically varying part:

$$V(j) = U(j) + \epsilon(j). \quad (4)$$

The fluctuating part ϵ shall be extreme-value distributed, so that the maximum of two extreme-value-distributed variables is again extreme-value distributed. (One could say the extreme value distribution is the “*natural*” distribution for extreme value problems in the same way as the Gaussian distribution is the “normal” distribution for sums of variables.) The parameter T is directly related to the variance of the extreme value distribution (which is sometimes also called Gumbel, Weibull, or Gnedenko distribution [18,19]). If individuals choose the alternative j with the highest total utility $V(i) > V(j)$ for all $j \neq i$, the probability of selecting alternative i is again given by formula (3). Therefore, probabilistic decision behavior can be interpreted as effect of incomplete or uncertain information.

In the following, we will introduce several generalizations of the above multinomial logit model. By

$$p_a(i, t) = \frac{e^{U_a(i, t)/T_a(t)}}{\sum_{i'} e^{U_a(i', t)/T_a(t)}}, \quad (5)$$

we take into account a possible dependence of T and $U(i)$ on the time t . Moreover, we distinguish different homogeneous subgroups a reflecting different personalities, character traits, or social backgrounds. For members of the same subgroup, the parameters T_a and utilities $U_a(i)$ are assumed to be approximately the same, while there are usually significant differences between subgroups. These originate partly from the fact that the utility $U(i)$ is composed of two parts $S_a(i)$ and $R_a(i)$ [18,19]:

$$U_a(i, t) = S_a(i, t) + R(i, t). \quad (6)$$

$S_a(i, t)$ reflects the *personal preferences* or the satisfaction resulting from decision i , while $R(i, t)$ describes the *social reinforcement*, i.e. the social support or punishment an individual must expect as a consequence of decision i . It is known that individuals show a tendency to increase the *consistency* between their attitudes, behaviours, and social environment [20–24]. Therefore, three different ways of maximizing the utility are observed:

- The individual can decide for a behavior i' with $S_a(i', t) > S_a(i, t)$ instead of for behavior i .

- If, due to *social pressure* $R(i, t) < 0$, an individual takes a decision i' which does not agree with his/her attitudes, this will eventually change the assessment $S_a(i', t)$ of alternative i' . This phenomenon is known from psychology as *dissonance reduction* [24,25]. (By the way, an attitude change does not occur in the case of a sufficiently high social reward for a behavior i' that is in disagreement with his/her attitudes!)
- The individual can also look for a social environment which has a positive attitude towards decision i : ‘Birds of a feather flock together.’

Another generalization will be the application of the above multi-nomial logit model to *decision changes* from the present alternative i to a new one i' . That is, we will introduce the *conditional* or *transition probability*

$$p_a(i'|i, t) = \frac{e^{U_a(i'|i, t)/T_a(t)}}{\sum_{i''} e^{U_a(i''|i, t)/T_a(t)}}, \quad (7)$$

for an individual of group a to select alternative i' after i , and express it in terms of a *relative* or *conditional utility function* $U_a(i'|i, t)$ given an individual of group a presently pursues strategy i . The idea is that individuals try to improve their situation compared to the present one.

Let us now decompose this relative utility into a symmetric part

$$S_a(i'|i, t) = \frac{U_a(i'|i, t) + U_a(i|i', t)}{2} = S_a(i|i', t) \quad (8)$$

and an antisymmetric part

$$A_a(i'|i, t) = \frac{U_a(i'|i, t) - U_a(i|i', t)}{2} = -A_a(i|i', t). \quad (9)$$

We can, then, write

$$p_a(i'|i, t) = \frac{e^{A_a(i'|i, t)/T_a(t)}}{e^{-S_a(i'|i, t)/T_a(t)}} \bigg/ \sum_{i''} \frac{e^{A_a(i''|i, t)/T_a(t)}}{e^{-S_a(i''|i, t)/T_a(t)}}. \quad (10)$$

Herein, the contribution

$$D_a(i, i', t) = e^{-S_a(i'|i, t)/T_a(t)} = D_a(i', i, t) \quad (11)$$

can be interpreted as *effective distance* or *dissimilarity*, reflecting *transaction costs* $S_a(i'|i, t)$. Since the formula (10) still contains as many parameters as the conditional transition probability $p_a(i'|i, t)$, it is just another representation, but not yet a model. Possible approaches to reduce the number of parameters are, for example, the assumption of time-independent symmetric transaction costs

$$S_a(i, i', t) = S_a(i, i) = S_a(i', i) \quad (12)$$

(which implies time-independent effective distances for a constant parameter $T_a(t) = T_a$) and/or

$$A_a(i'|i, t) = U_a(i', t) - U_a(i, t). \quad (13)$$

That is, the asymmetrical part $A_a(i'|i, t)$ would describe a *utility gain*. The resulting formula for the transition probability is

$$p_a(i'|i, t) = \frac{e^{[U_a(i', t) - U'_a(i, t)]/T_a(t)}}{D_a(i, i', t)} = \underbrace{\frac{1}{D_a(i, i', t)}}_{\text{Distance factor}} \underbrace{e^{U_a(i', t)/T_a(t)}}_{\text{Pull factor}} \underbrace{e^{-U'_a(i, t)/T_a(t)}}_{\text{Push factor}} \quad (14)$$

with the effective distance

$$D_a(i, i', t) = e^{-S_a(i, i')/T_a(t)} \quad (15)$$

and the assessment

$$\begin{aligned} U'_a(i, t) &= U_a(i, t) + T_a(t) \ln \sum_{i''} \frac{e^{[U_a(i'', t) - U_a(i, t)]/T_a(t)}}{D_a(i, i'', t)} \\ &= T_a(t) \ln \sum_{i''} \frac{e^{U_a(i'', t)/T_a(t)}}{e^{-S_a(i, i'')/T_a(t)}}. \end{aligned} \quad (16)$$

According to Eq. (14), the transition probability decreases with the dissimilarity $D_a(i, i', t)$ of two alternatives, but it increases with the *pull factor* (a high utility $U_a(i', t)$ of the new alternative i') and with the *push factor* (a low assessment $U'_a(i, t)$ of the previously chosen alternative i). (For a discussion of the so-called *shadow costs* related to the difference between $U_a(i', t)$ and $U'_a(i, t)$ see Ref. [26].) In order to have uniquely defined utilities, one normally sets the average utility equal to zero or, equivalently,

$$\sum_{i'} U_a(i, t) = 0. \quad (17)$$

Note that formula (5) is a special case of Eq. (14), resulting for identical effective distances $D_a(i, i', t) = D_a(t)$. The main advantage of the more general approach of the conditional decision probabilities is that they take into account transaction costs or the effective distance between two alternatives. We will see later on that this is quite important for certain applications (see Sec. 3).

2.3 Are Decisions Phase Transitions?

Decisions are *discontinuous changes* of the behavior after a period of *critical fluctuations* (repeatedly changing one's mind) and of *critical slowing down* (hesitation to take the decision). This suggests that decisions are phase transitions [18,19].

In the following, we will develop a more detailed picture of the decision-making process based on experimental observations [27,28] (for more details see Chap. 6 in Ref. [18,19]). According to Feger [27,28] decisions are *conflict situations* occurring when we can choose between several mutually exclusive *behavioral alternatives* i . At the beginning of such a conflict we estimate its *importance*. This is decisive for the time spent on decision-making.

Assume we are confronted with a complex and new situation that requires to take a decision rather than just a reflexive or automatic reaction to a standard situation (as in car driving or avoidance behavior of pedestrians). Then, a detailed consideration of the pros and cons of the different available alternatives is necessary. A large number of brain variables are involved into this consideration process, and there is some experimental evidence that they (may) show a chaotic dynamics [29,30]. In this way, we are normally exploring a *multi-dimensional assessment space* [31,18,19] rather than a one-dimensional scale of options. Some areas of this assessment space are in favour of one decision, others in favour of another decision (while some may be neutral or irrelevant for the specific decision). These areas could be interpreted as *basins of attraction* of the different decision alternatives. They do not need to be connected areas, but may be *fractal sets* as well. When moving through this assessment space during the consideration phase, the “relative sizes” (i.e. the measures) of these areas determine the occurrence probabilities of pros for the different alternatives. These can be ranked and thereby allow us to define a one-dimensional preference scale, although *the decision-making process is clearly a probabilistic process and normally not consistent with transitivity relations* (remember the multi-dimensional and possibly *fractal* assessment space). Therefore, transitivity only applies to particular (probably simple) decisions.

To be more specific, assume that the brain variables involved into the consideration process produce a random series l_0, l_1, l_2, \dots of (consciously) imagined, *anticipated consequences* of the possible decisions, and let l_k be in favour of decision $i = f(l_k)$. There is experimental evidence [27,28] that a decision is taken if K consecutive arguments $l_{k'+1}, \dots, l_{k'+K}$ are in favour of the *same* decision $i = f(l_{k'+1}) = \dots = f(l_{k'+K})$. Note that the number K depends on the available *decision time* and the *importance of the decision*, which may be group-specific and time-dependent. Therefore, we replace K by $K_a(t)$ in the following. Finally note that a comparison of the consequences of alternative decisions continues even *after* a decision was made. This is experienced as *doubts* about the rightness of the decision.

2.4 Fast and Slow Decisions

Let $p'_a(i'|i, t)$ be the occurrence probability of pros for alternative i' , if the individual has previously chosen alternative i . We may then define *preferences* $U'_a(i'|i, t) = \ln p'_a(i'|i, t)$ such that

$$p'_a(i'|i, t) = e^{U'_a(i'|i, t)} \geq 0. \quad (18)$$

According to the above, the probability $p_a(i'|i, t)$ of deciding for alternative i' is equal to the probability of $K_a(t)$ successive favourable arguments for i' , i.e.

$$p_a(i'|i, t) = e^{U''_a(i'|i, t)} = [p'_a(i'|i, t)]^{K_a(t)} = e^{K_a(t)U'_a(i'|i, t)} \quad (19)$$

with

$$U''_a(i'|i, t) = \ln p_a(i'|i, t) = K_a(t)U'_a(i'|i, t). \quad (20)$$

Note that, in contrast to non-exponential approaches, the expression (19) has a invariant functional form (namely, an exponential one), which is independent of the specific value of $K_a(t)$. The requirement of having several pros before a decision is made does not only reduce the risk of accidentally choosing an alternative with small preference $U'_a(i'|i, t)$. It also *magnifies* the differences in the utilities of different alternatives i' and i'' [18,19] because of

$$U''_a(i'|i, t) - U''_a(i''|i, t) = K_a(t)[U'_a(i'|i, t) - U'_a(i''|i, t)]. \quad (21)$$

Consequently, when $K_a(t)$ is reduced, there is a higher likelihood to decide for an alternative for which we have a lower preference. To avoid this, $K_a(t)$ is larger when the decision is important, as stated above. However, if the number of alternatives is large, the decision-making process takes particularly long (which is known as the *pain of choice*). Therefore, decision-making processes can not always be completed, especially if there is a deadline or a pressure of time. In such cases, the value of $K_a(t)$ is reduced, resulting in a different decision distribution. Because of

$$K_a(t)U'_a(i'|i, t) = U_a(i'|i, t)/T_a(t) - \ln \sum_{i''} e^{U_a(i''|i, t)/T_a(t)}, \quad (22)$$

$T_a(t)$ is basically proportional to $1/K_a(t)$. That is, the decision distribution becomes more and more similar to a uniform distribution (equi-distribution), when the time spent on the decision is reduced. In principle, this comes close to tossing a coin, which is exactly what people tend to do when they do not have enough time to take a well-founded decision. It would, therefore, be interesting to investigate the quality of decision-making by managers, as their time budget per decision tends to be short. On the other hand, experience plays a role, as a small uncertainty $T_a(t)$ of information can compensate for a shortage of time.

2.5 Complete and Incomplete Decisions

There are other situations of *incomplete decision-making*, where individuals would or actually do run out of time. In such cases, it appears that a spontaneous decision is taken “out of the stomach”. This could be the alternative which got the highest relative weight in the previous, unfinished consideration process, but it could also orient at the decisions of others based on the respective levels of sympathy or trust. We should underline three points here:

- The brain executes geometric averaging, which corresponds to an arithmetic average of the logarithms of $p'_a(i'|i, t)$ [11], i.e. of the utilities $U'_a(i'|i, t)$, so that the formula for the resulting decision probability may look similar to (19). The logarithmic scaling of physical stimuli, by the way, relates the decision probability to the power-law *Cobb-Douglas function* [32,33], as is shown in Ref. [18,19].
- *Emotionally loaded arguments* (re-)occur more frequently than others. Therefore, they have a higher impact on incomplete decision-making processes than on complete ones.

- When there is not enough time to complete a decision, imitative or avoidance behavior (see Sec. 2.10) play an important role.

Empirical research should focus on the investigation of incomplete decisions, as they are quite common in our everyday life.

2.6 The Red-Bus-Blue-Bus Problem

We have seen that the exponential approach is favourable for the derivation of the multi-nomial logit model and its properties. Modified approaches have been mainly developed because of the so-called *red-bus-blue-bus problem* [13]. It occurs when the decision alternatives are not completely exclusive, for example, when alternative busses have different colors or when alternative routes share common parts. In such cases, certain areas of the assessment space are in favour of *several* (say, j) of the alternatives. These areas are equally shared among the alternatives (i.e., divided by j), thereby reducing the resulting decision probabilities and the related preferences. We may take this into account by means of weight factors w_i (with $0 \leq w_i \leq 1$). If w_i^j denotes the part of the characteristics (favourable assessment space areas) that alternative i shares with $j - 1$ of the I alternatives, the correct formula should be

$$w_i = \sum_{j=1}^I \frac{w_i^j}{j} \quad \text{with} \quad \sum_{j=1}^I w_i^j = 1. \quad (23)$$

However, there is no general and simple formula to determine w_i^j (see Ref. [34] for a related treatment of route choice behavior). The corresponding formula for the (conditional) decision probability reads

$$p_a(i'|i, t) = \frac{w_{i'} e^{U_a(i', t)/T_a(t)} / D_a(i, i', t)}{\sum_{i''} w_{i''} e^{U_a(i'', t)/T_a(t)} / D_a(i, i'', t)}. \quad (24)$$

Note that the weights $w_{i'}$ could alternatively be taken into account in the calculation of $U_a(i', t)$.

2.7 The Freedom of Decision-Making

A subject of particular interest in connection with decision conflicts is what we denote as the *freedom of decision-making*. One important precondition for the freedom of decision-making is a not fully externally determined outcome of decisions, i.e. it should not be predictable in a reliable way. This precondition is certainly fulfilled, although we know that certain decisions are more likely than others. The above introduced, probabilistic decision model is consistent with this. According to it, the respective decision is a result of the internal dynamics of the brain variables, which is to certain degree stochastic or chaotic. Whether this result is voluntary depends on whether the brain dynamics can be mentally controlled in a more or less arbitrary way. Recent measurements of neural activity

seem to indicate that a decision is made (for example, body motion is initiated) before the conscious feeling of a free decision arises [35,36]. This feeling could, therefore, be an interpretation or *rationalization* of our emergent behavior.

According to psychological investigations the subjectively felt freedom of decision-making increases with the *uncertainty* with respect to the final result of a decision [37,38]. That is, the freedom of decision-making is an *entropy-like* quantity. It is greater the larger the number of alternatives is and the more equivalent they are (with regard to the related preferences). A restriction of the freedom of decision-making gives rise to *reactance* (i.e. to a kind of a *defiant reaction*). Either the limitation of freedom will be evaded if possible, or *resistance* is formed [25,39–41].

2.8 Master Equation Description of Dynamic Decision Behavior

We will now discuss a stochastic description of dynamic decision behavior along the lines suggested by Weidlich [42–44]. Let us assume we have N_a individuals in group a , and a considered population of altogether

$$N = \sum_a N_a \quad (25)$$

persons. The so-called *occupation number* $n_i^a(t)$ shall denote how many individuals of group a pursue alternative i at time t , i.e. we have

$$\sum_i n_i^a(t) = N_a. \quad (26)$$

The *socio-configuration*

$$\mathbf{n} = (n_1^1, n_2^1, \dots, n_i^1, \dots, n_1^2, \dots, n_i^2 \dots) \quad (27)$$

does, then, comprise the distribution of all N individuals over the different groups a and states i . We will represent the probability of finding the socio-configuration \mathbf{n} at time t by $P(\mathbf{n}, t)$. This probability is reduced by transitions to other configurations \mathbf{n}' , whose frequencies are proportional to $P(\mathbf{n}, t)$. The proportionality factor is the *conditional probability* or (*configurational*) *transition probability* $P(\mathbf{n}', t + \Delta t | \mathbf{n}, t)$ of finding the configuration \mathbf{n}' at time $(t + \Delta t)$, given that we have the configuration \mathbf{n} at time t . Conversely, the probability $P(\mathbf{n}, t)$ increases by transitions from configurations \mathbf{n}' to \mathbf{n} , which are proportional to the occurrence probabilities $P(\mathbf{n}', t)$ of the socio-configurations \mathbf{n}' and to the transition probabilities $P(\mathbf{n}, t + \Delta t | \mathbf{n}', t)$. The resulting balance equation governing the dynamics of the above specified *Markov chain* reads

$$P(\mathbf{n}, t + \Delta t) - P(\mathbf{n}, t) = \sum_{\mathbf{n}'} P(\mathbf{n}, t + \Delta t | \mathbf{n}', t) P(\mathbf{n}', t) - \sum_{\mathbf{n}'} P(\mathbf{n}', t + \Delta t | \mathbf{n}, t) P(\mathbf{n}, t) \quad (28)$$

or, considering the normalization

$$\sum_{\mathbf{n}'} P(\mathbf{n}', t + \Delta t | \mathbf{n}, t) = 1 \quad (29)$$

of the transition probabilities,

$$P(\mathbf{n}, t + \Delta t) = \sum_{\mathbf{n}'} P(\mathbf{n}, t + \Delta t | \mathbf{n}', t) P(\mathbf{n}', t). \quad (30)$$

In the continuous limit $\Delta t \rightarrow 0$, we obtain the so-called *master equation*

$$\frac{dP(\mathbf{n}, t)}{dt} = \underbrace{\sum_{\mathbf{n}'(\neq \mathbf{n})} W(\mathbf{n}|\mathbf{n}', t) P(\mathbf{n}', t)}_{\text{Inflow into } \mathbf{n}} - \underbrace{\sum_{\mathbf{n}'(\neq \mathbf{n})} W(\mathbf{n}'|\mathbf{n}, t) P(\mathbf{n}, t)}_{\text{Outflow from } \mathbf{n}}, \quad (31)$$

where we have introduced the (*configurational*) *transition rates*

$$W(\mathbf{n}|\mathbf{n}', t) = \lim_{\Delta t \rightarrow 0} \frac{P(\mathbf{n}, t + \Delta t | \mathbf{n}', t)}{\Delta t} \quad \text{for } \mathbf{n}' \neq \mathbf{n}. \quad (32)$$

Note that the *master equation* (31) assumes the *Markov property* according to which the conditional probabilities $P(\mathbf{n}, t + \Delta t | \mathbf{n}', t)$ depend on t and Δt only, but not on previous time steps. However, a *generalized master equation* for problems with *memory effects* exists, see Ref. [18,19,45]. It reads

$$\frac{dP(\mathbf{n}, t)}{dt} = \int_{-\infty}^t dt' \sum_{\mathbf{n}'(\neq \mathbf{n})} W_{t-t'}(\mathbf{n}|\mathbf{n}', t) P(\mathbf{n}', t-t') - W_{t-t'}(\mathbf{n}'|\mathbf{n}, t) P(\mathbf{n}, t-t') \quad (33)$$

with memory-dependent transition rates $W_{t-t'}(\mathbf{n}'|\mathbf{n}, t) P(\mathbf{n}, t-t')$. For example, for an exponentially decaying memory with decay rate τ we could use the formula

$$W_{t-t'}(\mathbf{n}'|\mathbf{n}, t) = W(\mathbf{n}'|\mathbf{n}, t') \frac{1}{\tau} \exp\left(-\frac{t-t'}{\tau}\right). \quad (34)$$

2.9 Mean Field Approach and Boltzmann Equation

It is often useful to consider the mean value equations for the expected values $\langle n_i^a \rangle = \sum_{\mathbf{n}} n_i^a P(\mathbf{n}, t)$, which are obtained by multiplying Eq. (31) with n_i^a , summing up over \mathbf{n} , and suitably interchanging \mathbf{n} and \mathbf{n}' :

$$\frac{d\langle n_i^a \rangle}{dt} = \sum_{\mathbf{n}} n_i^a \frac{dP(\mathbf{n}, t)}{dt} = \sum_{\mathbf{n}} \sum_{\mathbf{n}'} (n_i^a - n_i^a) W(\mathbf{n}'|\mathbf{n}, t) P(\mathbf{n}, t) = \langle m_i^a(\mathbf{n}, t) \rangle. \quad (35)$$

Here, we have introduced the *first jump moments*

$$m_i^a(\mathbf{n}, t) = \sum_{\mathbf{n}'} (n_i^a - n_i^a) W(\mathbf{n}'|\mathbf{n}, t). \quad (36)$$

Let us now assume *spontaneous decisions* with transition rates $w_a(i|i, t)$ from alternative i to i' by individuals of group a and, in addition, *pair interactions* between two individuals belonging to groups a and b , leading to a change from

alternative i to i' by the a -individual and from j to j' by the b -individual with a transition rate of $w_{ab}(i', j'|i, j, t)$. Defining the resulting socio-configurations

$$\mathbf{n}_{i' i'}^{aa} = (n_1^1, n_2^1, \dots, n_1^a, \dots, n_{i-1}^a, n_i^a - 1, n_{i+1}^a, \dots, n_{i'-1}^a, n_{i'}^a + 1, n_{i'+1}^a, \dots), \quad (37)$$

$$\mathbf{n}_{i' i' j j'}^{aa bb} = (n_1^1, \dots, n_1^a, \dots, n_i^a - 1, \dots, n_{i'}^a + 1, \dots, n_j^b - 1, \dots, n_{j'}^b + 1, \dots), \quad (38)$$

the corresponding configurational transition rates are given by

$$W(\mathbf{n}'|\mathbf{n}, t) = \begin{cases} w_a(i'|i, t)n_i^a & \text{if } \mathbf{n}' = \mathbf{n}_{i' i'}^{aa}, \\ w_{ab}(i', j'|i, j, t)n_i^a(n_j^b - \delta_{ij}^{ab}) & \text{if } \mathbf{n}' = \mathbf{n}_{i' i' j j'}^{aa bb}, \\ 0 & \text{otherwise.} \end{cases} \quad (39)$$

Herein, $\delta_{ij}^{ab} = 1$ if $a = b$ and $i = j$ (to avoid self-interactions), but 0 otherwise. According to formula (39), the total rate of spontaneous transitions is proportional to the number n_i^a of individuals of group a who may change their previous decision i independently of each other, while the total rate of pair interactions is proportional to the number $n_i^a(n_j^b - \delta_{ij}^{ab})$ of possible interactions between a - and b -individuals pursuing alternatives i and j . Inserting Eq. (39) into (36) eventually leads to

$$\begin{aligned} m_i^a(\mathbf{n}, t) &= \sum_{i'} \left[w_a(i|i', t) + \sum_b \sum_{j, j'} w_{ab}(i, j|i', j', t)n_{j'}^b \right] n_{i'}^a \\ &\quad - \sum_{i'} \left[w_a(i'|i, t) + \sum_b \sum_{j, j'} w_{ab}(i', j'|i, j, t)n_j^b \right] n_i^a, \end{aligned} \quad (40)$$

if δ_{ij}^{ab} is negligible (see, for example, Refs. [18,19]). The *mean field approach* assumes

$$\langle m_i^a(\mathbf{n}, t) \rangle \approx m_i^a(\langle \mathbf{n} \rangle, t), \quad (41)$$

i.e., that the system dynamics is determined by the mean value $\langle \mathbf{n} \rangle$, which is true for a sharply peaked, unimodal distribution $P(\mathbf{n}, t)$. This leads to the generalized *Boltzmann equation*

$$\begin{aligned} \frac{dP_a(i, t)}{dt} &= \sum_{i'} \left[w_a(i|i', t) + \sum_b \sum_{j, j'} \tilde{w}_{ab}(i, j|i', j', t)P_b(j', t) \right] P_a(i', t) \\ &\quad - \sum_{i'} \left[w(i'|i, t) + \sum_b \sum_{j, j'} \tilde{w}_{ab}(i', j'|i, j, t)P_b(j, t) \right] P_a(i, t), \end{aligned} \quad (42)$$

where we have introduced the (*expected*) *occurrence probabilities* $P_a(i, t) = \langle n_i^a \rangle / N_a$ of decisions i in group a and $\tilde{w}_{ab}(i', j'|i, j, t) = N_b w_{ab}(i', j'|i, j, t)$ [18,19,46,47]. Note that this Boltzmann equation neglects the covariances

$$\sigma_{ij}^{ab}(t) = \langle (n_i^a - \langle n_i^a \rangle)(n_j^b - \langle n_j^b \rangle) \rangle = \langle n_i^a n_j^b \rangle - \langle n_i^a \rangle \langle n_j^b \rangle \quad (43)$$

and the corresponding correlations

$$r_{ij}^{ab}(t) = \sigma_{ij}^{ab}(t) / \sqrt{\sigma_{ii}^{aa}(t)\sigma_{jj}^{bb}(t)}. \quad (44)$$

For the derivation of corrected mean value equations (taking into account contributions by the covariances), see Ref. [48,18,19]. Without corrections, the above Boltzmann equation can be interpreted as the systematic component of a *Langevin equation* describing the *most probable* decision changes.

2.10 Specification of the Transition Rates of the Boltzmann Equation

In the previous section, we have derived an equation for the temporal change of the occurrence probabilities $P_a(i, t)$ of the decisions i in group a . Simplifying the above expressions, we can write

$$\frac{dP_a(i, t)}{dt} = \underbrace{\sum_{i'} w^a(i|i', t)P_a(i', t)}_{\text{Inflow into } i} - \underbrace{\sum_{i'} w^a(i'|i, t)P_a(i, t)}_{\text{Outflow from } i} \quad (45)$$

with the (*effective*) *transition rates*

$$w^a(i'|i, t) = w_a(i'|i, t) + \sum_b \sum_{j, j'} \tilde{w}_{ab}(i', j'|i, j, t)P_b(j, t). \quad (46)$$

These have to be specified for social interactions, now. There is a detailed theory how to do this [18,19,46,47,49], but here we will only write down the finally resulting formula. Assume that $\nu_{ab}^1(t) = \nu_{ab}(t)r_{ab}^1(t)$ is the rate of *imitation processes* of an a -individual due to interactions with b -individuals, and $\nu_{ab}^2(t) = \nu_{ab}(t)r_{ab}^2(t)$ the analogous rate of *avoidance processes*. These rates are products of the *interaction rate* ν_{ab} of an a -individual with b -individuals, which depends on the *social interaction network* [50–52], and of the relative frequencies $r_{ab}^1(t)$ and $r_{ab}^2(t)$ of imitative and avoidance processes, respectively.

Now, let $p^a(i'|i, t)$ be the probability to change from alternative i to i' as discussed in Sec. 2.2. The effective transition rate has, then, the form

$$w^a(i'|i, t) = w_a(i'|i, t) + p^a(i'|i, t) \sum_b [\nu_{ab}^1(t)P_b(i', t) + \nu_{ab}^2(t)P_b(i, t)], \quad (47)$$

because the imitation rate is proportional to the occurrence probability $P_b(i', t)$ of the imitated decision i' , and the avoidance rate is proportional to the occurrence probability $P_b(i, t)$ of the presently pursued alternative i [18,19].

Finally, we can write

$$w_a(i'|i, t) = \nu_a^0(t)p_a(i'|i, t), \quad (48)$$

where $\nu_a^0(t)$ denotes the rate of *spontaneous* decision changes. If the transition probabilities $p_a(i'|i, t)$ and $p^a(i'|i, t)$ of spontaneous and interactive decision changes are the same, the formula for the effective transition rate simplifies:

$$w^a(i'|i, t) = p_a(i'|i, t) \left\{ \nu_a^0(t) + \sum_b [\nu_{ab}^1(t)P_b(i', t) + \nu_{ab}^2(t)P_b(i, t)] \right\}. \quad (49)$$

It makes sense to specify $p_a(i'|i, t)$ in accordance with Eq. (14).

Imitation is a very common human behavior. One also speaks of *herding behavior* [53], *bandwagon effect*, or *persuasion* [54]. Avoidance behavior is sometimes called *defiance* or *snobbish behavior*. It originates from the desire of humans to distinguish from people with different backgrounds. Note that *homo economicus* should not show avoidance or imitation behavior at all, but decide on a rational basis. Nevertheless, there are good reasons for this behavior. In many situations, we do not have enough time to collect and evaluate the information for a rational decision (see Sec. 2.5). (Just imagine we would really try to compare all contracts of insurance companies.) Therefore, we rely on the experience of others. The wide spreading of imitation and avoidance behavior is due to the great success of *learning by observation*, which has its roots in *evolution*. It allows us to avoid painful experiences and helps to learn faster. Therefore, we tend to imitate (successful) decisions of people who are in a similar situation as we are. Some indicator for similarity is sympathy, as we tend to like people whose background is comparable. In contrast, we may show avoidance behavior with respect to people we dislike, because we expect their decisions to be counterproductive. That is, emotions are helpful in cases where we cannot complete our decisions. Altogether, the combination of individual assessment with imitation and avoidance behavior may be viewed as *collective problem solving* [1,55–57]. It allows us to cope with situations which one individual cannot handle on time due to the limited capacities of information collection and data processing.

3 Fields of Application

The Boltzmann equation was originally developed for the description of particle collisions in gases, but the mathematically related description of social interactions has a wide range of applications. It turns out that many dynamical models that have been proposed, used, and tested in the social sciences, are special cases of the above generalized Boltzmann equation.

3.1 The Logistic Equation

Imagine a situation with one group $a = 1$ and $I = 2$ alternatives, where only spontaneous and imitative decision changes play a role. Then, we obtain an equation of the form

$$\frac{dP_1(1, t)}{dt} = C_0 + C_1 P_1(1, t) + C_2 P_1(1, t)^2 \quad (50)$$

with constants C_0 , C_1 , and C_2 given by the transition rates $w(\dots)$ [18,19,49]. Introducing the scaling $z(t) = P_1(1, t) - C$ with $C = (-C_1 - \sqrt{(C_1)^2 - 4C_0C_2})/(2C_2)$, the (initial) growth rate $r = C_1 - 2C_2C$, and the capacity $z_0 = r/C_2$, one arrives at the *logistic equation* [58,59]

$$\frac{dz(t)}{dt} = rz(t)[1 - z(t)/z_0], \quad (51)$$

which describes many kinds of *limited growth processes* [60–63].

3.2 The Generalized Gravity Model and its Application to Migration

A quite successful model to estimate the *origin-destination matrices* describing flows of goods, persons, cars, etc. between locations i and i' is the *generalized gravity model* [18,19,49]

$$w^a(i'|i, t)P_a(i, t) = \sum_b \nu_{ab}^1(t) e^{[U_a(i', t) - U_a(i, t)]/T_a} \frac{P_b(i', t)P_a(i, t)}{D_a(i, i')}. \quad (52)$$

In the case of one single population $a = 1$, we have

$$w^1(i'|i, t)P_1(i, t) \propto \frac{P_1(i', t)P_1(i, t)}{D_1(i, i')}, \quad (53)$$

which looks similar to the law of gravitation and explains the name of the model [64,65]. It reflects that, for example, the person flow from place i to i' is proportional to the number of people living at location i (who can travel) and proportional to the number of people in the destination town they may meet, but the number of trips goes down with the effective distance.

Note that it was very successful to apply the above model to migration between different regions [66,67,18,19,49]. The fitted utilities even mirrored political events such as the construction of the Berlin wall. Despite of a data reduction by 87.2% corresponding to only 1.28 data values per year, the correlation with the migration data was very high, namely $r = 0.985$ [18,19,49].

3.3 Social Force Models and Opinion Formation

In this section, we will assume a continuous and m -dimensional decision space. For this reason, we will replace i by \mathbf{x} , i' by \mathbf{x}' , and sums $\sum_{i'}$ by integrals $\int d^m x'$. Moreover, we require that decision changes mostly occur in small steps (i.e. $w^a(\mathbf{x}'|\mathbf{x}, t) \approx 0$ if $\|\mathbf{x}' - \mathbf{x}\|$ is large). Then, it is possible to derive a *Boltzmann-Fokker-Planck* equation by second order Taylor approximation of the above Boltzmann equation. This equation is equivalent to a certain *stochastic differential equation* or *Langevin equation* describing the decision changes of the single individuals α belonging to group a [18,19,49,68]. It reads:

$$\frac{d\mathbf{x}_\alpha(t)}{dt} = \mathbf{f}_a(\mathbf{x}_\alpha, t) + \text{individual fluctuations}. \quad (54)$$

Herein, the vector

$$\mathbf{f}_a(\mathbf{x}, t) = \int d^m x' (\mathbf{x}' - \mathbf{x}) w^a(\mathbf{x}'|\mathbf{x}, t) \quad (55)$$

has the interpretation of a (non-Newtonian) *social force* [69], which determines the size and direction of the systematic part of decision changes [70,18,19,49,68]. Note that this social force does not only affect the individual behavior, but also

changes with the decision distributions $P_b(\mathbf{x}, t)$. For the effective transition rates (47), for example, we get

$$\begin{aligned} \mathbf{f}_a(\mathbf{x}, t) = & \int d^m x' (\mathbf{x}' - \mathbf{x}) \left\{ w_a(\mathbf{x}'|\mathbf{x}, t) \right. \\ & \left. + p^a(\mathbf{x}'|\mathbf{x}, t) \sum_b [\nu_{ab}^1(t) P_b(\mathbf{x}', t) + \nu_{ab}^2(t) P_b(\mathbf{x}, t)] \right\} \end{aligned} \quad (56)$$

The distributions can be expressed in terms of the individual decisions via

$$P_b(\mathbf{x}, t) = \frac{1}{N_b} \sum_{\beta \in b} \delta(\mathbf{x} - \mathbf{x}_\beta(t)), \quad (57)$$

where $\delta(\mathbf{x} - \mathbf{x}_\beta)$ denotes a multivariate Gaussian distribution around \mathbf{x}_β with a small variance. Considering this allows us to decompose the social force into components due to spontaneous decision changes and due to pair interactions [18]:

$$\mathbf{f}_a(\mathbf{x}_\alpha, t) = \underbrace{\mathbf{f}_a^0(\mathbf{x}_\alpha, t)}_{\text{Spont. force}} + \underbrace{\sum_{\beta} [\mathbf{f}_{ab}^1(\mathbf{x}_\alpha, \mathbf{x}_\beta, t) + \mathbf{f}_{ab}^2(\mathbf{x}_\alpha, \mathbf{x}_\beta, t)]}_{\text{Pair interaction forces}} \quad (58)$$

with the *spontaneous force*

$$\mathbf{f}_a^0(\mathbf{x}_\alpha, t) = \int d^m x' (\mathbf{x}' - \mathbf{x}_\alpha(t)) w_a(\mathbf{x}'|\mathbf{x}_\alpha(t), t), \quad (59)$$

the *imitation force*

$$\begin{aligned} \mathbf{f}_{ab}^1(\mathbf{x}_\alpha, \mathbf{x}_\beta, t) &= \int d^m x' (\mathbf{x}' - \mathbf{x}_\alpha(t)) p^a(\mathbf{x}'|\mathbf{x}_\alpha(t), t) \frac{\nu_{ab}^1(t)}{N_b} \delta(\mathbf{x}' - \mathbf{x}_\beta(t)) \\ &= (\mathbf{x}_\beta(t) - \mathbf{x}_\alpha(t)) p^a(\mathbf{x}_\beta(t)|\mathbf{x}_\alpha(t), t) \frac{\nu_{ab}^1(t)}{N_b}, \end{aligned} \quad (60)$$

and the *avoidance force*

$$\mathbf{f}_{ab}^2(\mathbf{x}_\alpha, \mathbf{x}_\beta, t) = \int d^m x' (\mathbf{x}' - \mathbf{x}_\alpha(t)) p^a(\mathbf{x}'|\mathbf{x}_\alpha(t), t) \frac{\nu_{ab}^2(t)}{N_b} \delta(\mathbf{x}_\alpha(t) - \mathbf{x}_\beta(t)). \quad (61)$$

These expressions can be further evaluated, if $w_a(\mathbf{x}'|\mathbf{x}, t)$ and $p^a(\mathbf{x}'|\mathbf{x}, t)$ are specified. We also point out that the above social force model shares some common features with the *social impact theory* [52,71–74].

Social force models have been very successful in applications to vehicle traffic [75–77] and pedestrian flows [53,70,78,79]. Here, we will discuss an application to opinion formation. Let us assume two groups a of people distributed over a *one-dimensional opinion scale* between two extreme positions regarding a certain issue. The utilities and transaction costs determining the conditional decision probabilities $p_a(x'|x, t)$ are specified as follows [18,19,49,68]:

$$U_a(x, t) \propto - \left(\frac{x - x_a}{L_a} \right)^2 \quad \text{and} \quad S_a(x, x') \propto \frac{|x' - x|}{R}. \quad (62)$$

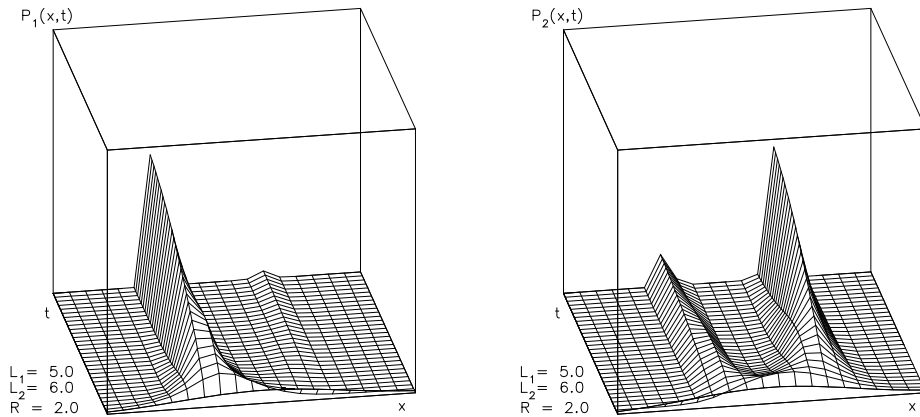

Fig. 1. Example of opinion formation of two groups with imitatively interacting individuals, when the tolerance L_a is small (from [18,19,49,68,80]). The opinion distributions $P_a(x,t)$ in both groups are bimodal. Most individuals decide for an opinion x close to their preferred opinion x_a , but some are convinced by the opinion preferred in the other group.

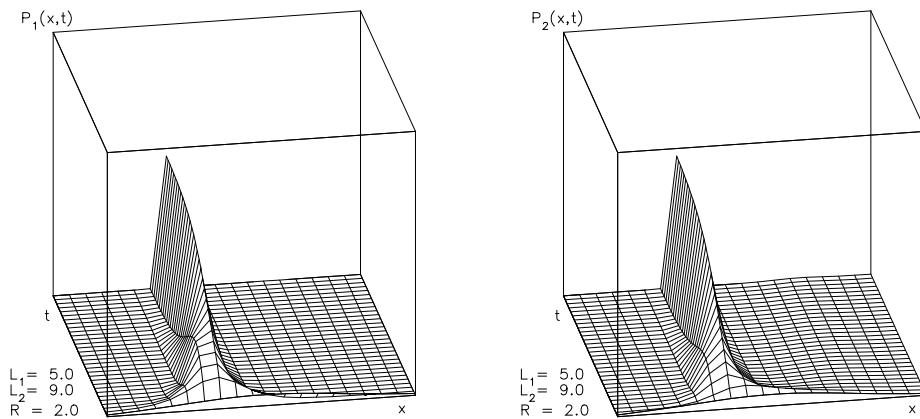

Fig. 2. As Fig. 1, but for a higher tolerance L_a (from [18,19,49,68,80]). The shape of the distributions $P_a(x,t)$ has now qualitatively changed from a bimodal to a unimodal form. This indicates a phase transition from imitative to compromising behavior at some critical value of tolerance. In both populations, the opinions are then distributed around a certain opinion x_0 , which agrees in both groups, but differs from both, x_1 and x_2 . Its location is closer to the preferred position x_1 in the group $a = 1$ with the smaller tolerance $L_1 < L_2$.

x_a has the meaning of the preferred position in group a , L_a is the tolerance of deviations from this position, and R the range of interaction. In the discussed examples, we neglect spontaneous transitions by setting $\nu_a^0(t) = 0$ and investigate

either imitative or avoidance interactions in accordance with the interaction rates

$$(\nu_{ab}^1(t)) = \begin{pmatrix} \nu & \nu \\ \nu & \nu \end{pmatrix} \quad \text{and} \quad \nu_{ab}^2(t) = 0 \quad (63)$$

or

$$\nu_{ab}^1(t) = 0 \quad \text{and} \quad (\nu_{ab}^2(t)) = \begin{pmatrix} 0 & \nu \\ \nu & 0 \end{pmatrix}. \quad (64)$$

A selection of numerical results is presented in Figs. 1 to 3. It is particularly interesting that, in the simulation of imitative behavior, we find a *phase transition to compromising behavior*, when the tolerance L_a is sufficiently large. For a more detailed discussion see Refs. [18,19,49,68].

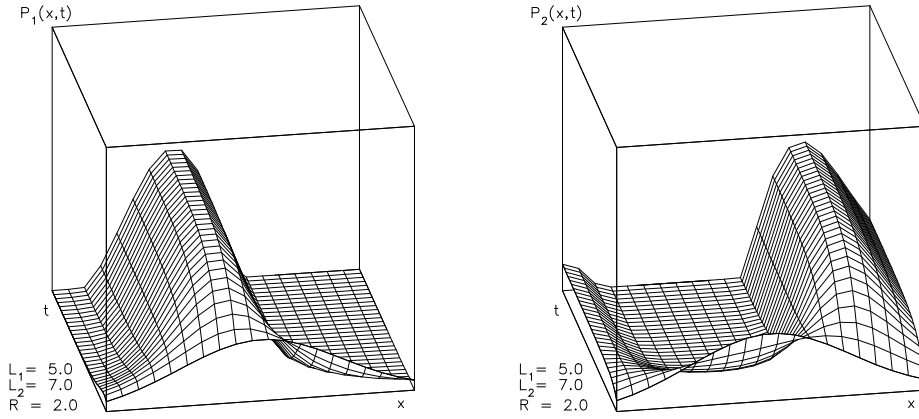

Fig. 3. Opinion distributions $P_a(x, t)$ for two groups a showing avoidance behavior, because the individuals in one group dislike the people of the respective other group (from [18,19,49,68,80]). As expected, there is almost no overlap between the opinion distributions $P_1(x, t)$ and $P_2(x, t)$ in the different groups. The tendency to avoid the opinions in the other group is so large that some people in group $a = 2$ even show opinions “left” of the ones found in group $a = 1$, although these are far away from the preferred position x_2 . This occurs due to their higher tolerance $L_2 > L_1$.

3.4 The Game-Dynamical Equations

The *game-dynamical equations*

$$\begin{aligned} \frac{dP_1(i, t)}{dt} = & \underbrace{\nu(t)P_1(i, t) \left[F(i, t) - \sum_{i'} F(i', t)P_1(i', t) \right]}_{\text{Selection}} \\ & + \underbrace{\sum_{i'} [w_1(i|i')P_1(i', t) - w_1(i'|i)P_1(i, t)]}_{\text{Mutation}} \end{aligned} \quad (65)$$

for behavioral changes [81–84] are an adoption of *selection-mutation equations* originally developed in evolutionary biology [85,86]. They describe the effects of spontaneous transitions (so-called *mutations*) and a *selection* of those strategies i whose *expected success* or so-called *fitness*

$$F(i, t) = \sum_{i''} P_{ii''} P_1(i'', t) \quad (66)$$

is higher than the average one, $\sum_{i'} F(i', t) P_1(i', t)$. Herein, $P_{ii''}$ denotes the *payoff* when strategy i is confronted with strategy i'' .

The game-dynamical equations have been very successful in explaining observations in behavioral biology, sociology, and economics. However, in contrast to evolutionary biology, a “microscopic” derivation based on individual interactions has been missing for a long time. This has been discovered in 1992 [48,87]. Inserting $\nu_{11}^2(t) = 0$ and the expression

$$\nu_{11}^1(t) p^1(i'|i; t) = \nu(t) \max(F(i', t) - F(i, t), 0) \quad (67)$$

into the Boltzmann equation (45) with the effective transition rates (47) exactly yields the game-dynamical equations because of

$$\max(F(i, t) - F(i', t), 0) - \max(F(i', t) - F(i, t), 0) = F(i, t) - F(i', t). \quad (68)$$

Formula (67) is nowadays called the *proportional imitation rule* [88], as it assumes that the transition probability $p^1(i'|i; t)$ is proportional to the expected gain $F(i', t) - F(i, t)$ in success, if this is positive, but zero otherwise. Note, however, that the game-dynamical equations can be also viewed as a first-order Taylor approximation of a Boltzmann-equation with an imitative transition probability of the form (47) with

$$D_1(i, i') = 2 \quad \text{and} \quad F(i, t) = \frac{U_1(i, t) + U_1'(i, t)}{2T_1(t)}. \quad (69)$$

In the following, we will discuss some applications of the game-dynamical equations, which can, by the way, be transformed [84] into mathematically equivalent *Lotka-Volterra equations* [89–91] used to describe *predator-prey* or other (ecological) *systems* [84,92–94].

3.5 Fashion Cycles and Deterministic Chaos

Now, assume one population $a = 1$, in which imitative decision changes take place between $I = 3$ kinds of *fashions* $i \in \{1, 2, 3\}$. If the payoff matrix is specified according to

$$(P_{ii''}) = \begin{pmatrix} 0 & -1 & 1 \\ 1 & 0 & -1 \\ -1 & 1 & 0 \end{pmatrix}, \quad (70)$$

it reflects that fashion i receives negative attention by people wearing fashion $(i + 1) \bmod I$ (the *avantgarde*), while it receives positive attention by people wearing fashion $(i - 1) \bmod I$ (being behind the present fashion).

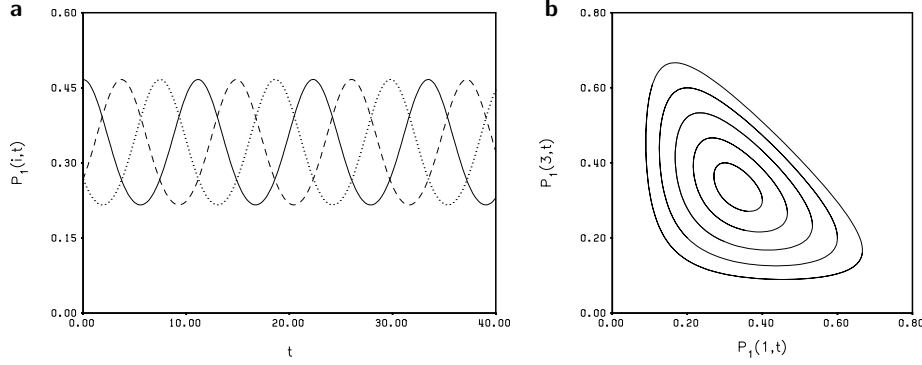

Fig. 4. Example of fashion cycles for the case of $I = 3$ fashions (from [18,19,47,95]). We observe non-linear and regular oscillations **(a)** in the plot of the time-dependent proportions $P_1(i, t)$ of the different fashions i and **(b)** in the phase portraits showing the proportion $P_1(3, t)$ of fashion $i = 3$ over the proportion $P_1(1, t)$ of fashion $i = 1$ for various initial conditions.

The corresponding game-dynamical equations are

$$\frac{dP_1(i, t)}{dt} = \nu P_1(i, t) [P_1((i-1) \bmod I, t) - P_1((i+1) \bmod I, t)]. \quad (71)$$

Apart from the *normalization condition*

$$\sum_{i=1}^I P_1(i, t) = 1, \quad (72)$$

these equations have an *invariant of motion*:

$$C = \prod_{i=1}^I P_1(i, t) = \text{const.} \quad (73)$$

For $I = 3$ it is, therefore, possible to calculate the exact form of the resulting *phase portraits* as a function of the initial conditions $P_1(i, 0)$, despite of the non-linearity of the differential equations (71):

$$P_1(2, t) = \frac{1 - P_1(1, t)}{2} \pm \sqrt{\left[\frac{1 - P_1(1, t)}{2} \right]^2 - \frac{C}{P_1(1, t)}}, \quad (74)$$

where $P_1(3, t) = 1 - P_1(1, t) - P_1(2, t)$ and $C = P_1(1, 0)P_1(2, 0)P_1(3, 0)$. This implies non-linear, but periodic (i.e. anharmonic) oscillations.

According to Eq. (74), there should always be the same sequence of fashions. This is, of course, not very realistic. However, for $I > 3$, we find a rather irregular sequence, as desired (see Fig. 5a). Note that, for certain specification of the payoff matrices, the equations for the most probable decision changes can show even more complex dynamical behavior such as *deterministic chaos* (see Fig. 5b). This implies that the decision distributions $P_a(i, t)$ would, for principal reasons, be *unpredictable* over a longer time period, even if we knew the transition rates $w^a(i'|i, t)$ exactly.

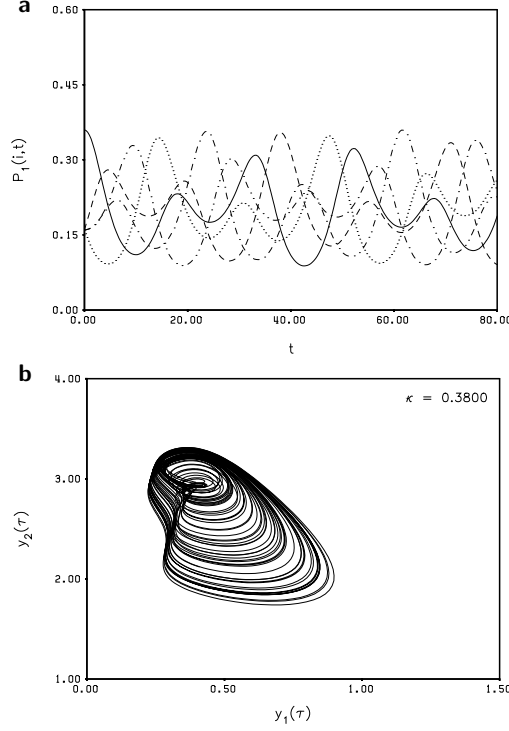

Fig. 5. (a) The non-linear oscillations for the case of $I = 5$ different fashions are irregular in the sense that they do not show short-term periodicity. **(b)** The decision dynamics can be chaotic (even if the decision dynamics is deterministic). This is illustrated by the plot of a chaotic attractor showing the result of another opinion formation model (a kind of periodically driven Brusselator) in scaled variables $y_a(\tau) = y_a^0 P_a(t)$ with $\tau = \tau_0 t$. For details see Refs. [18,19,46,47], from which these plots were reproduced.

3.6 Polarization, Mass Psychology, and Self-Organized Behavioral Conventions

In this subsection, we will assume individuals of one group $a = 1$ that can choose between $I = 2$ *equivalent* strategies, i.e. the payoff matrix is symmetric:

$$(P_{ii'}) = \begin{pmatrix} A+B & B \\ B & A+B \end{pmatrix}. \quad (75)$$

An example for equivalent strategies would, for example, be the avoidance of another pedestrian on the right-hand side ($i = 1$) or on the left-hand side ($i = 2$), see Fig. 6.

With a constant spontaneous transition or mutation rate $w(x|x') = W$ corresponding to *trial and error behavior*, we find the specific game dynamical equation

$$\frac{dP_a(i,t)}{dt} = -2 \left(P_a(i,t) - \frac{1}{2} \right) \left\{ W + \nu A P_a(i,t) [P_a(i,t) - 1] \right\}. \quad (76)$$

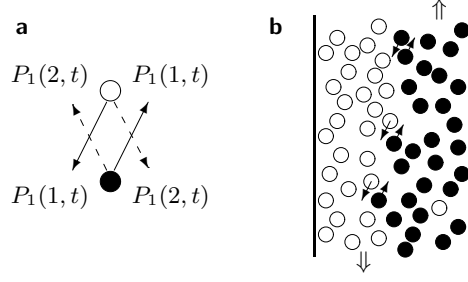

Fig. 6. (a) Illustration of the avoidance problem of two pedestrians walking in opposite directions. $P_1(1, t)$ represents the probability of deciding for an avoidance maneuver on the right-hand side, $P_1(2, t)$ the corresponding probability for the left-hand side. **(b)** Pedestrians subconsciously form lanes of uniform walking directions. In Central Europe, these lanes appear more frequently on the right-hand side, which can be interpreted as the result of a self-organized behavioral convention. (From [18,19,45,46,87,96]).

For $\kappa = 1 - 4W/(\nu A) \leq 0$, the only stationary solution is $P_a(i) = 1/2$. Otherwise this solution is unstable, but there are the two stable stationary solutions $P_a(i) = (1 + \sqrt{\kappa})/2$ and $P_a(i) = (1 - \sqrt{\kappa})/2$. The finally resulting solution depends on the (random) initial condition (i.e., basically on initial fluctuations). Thus, we find *symmetry-breaking* or, in other words, *history-dependent behavior* [18,19,45,46,48,70,87,96].

From the above, we may draw several interesting conclusions:

- If it is profitable to take the same decision as the interaction partner (i.e. $A > 0$), in each group a one of the equivalent strategies will win through, if the spontaneous transition rate W is small enough. This gives rise to a *self-organized behavioral convention*. Examples are the rotation direction of clocks, the pedestrians' asymmetric avoidance behavior [18,19,45,46,87,96], or the triumph of VHS over Beta video [97].
- A transition from *individualistic behavior* (where people choose independently among all available alternatives) to *herding behavior* or *mass psychology* (where people tend to join the decision of the majority) occurs when the parameter κ becomes positive. This can happen, if the advantage A or the interaction rate ν increase for some reason, or if the rate W of spontaneous decision changes (i.e. the readiness to check out other alternatives) goes down.
- If we distinguish several weakly interacting groups a , for example people with separate social backgrounds living in different parts of a city or country, the alternative $i = 1$ may gain the majority in some groups, and the alternative $i = 2$ in others, if $\kappa > 0$. This corresponds to a *polarization* of society, which is common for emotional topics, possibly because of the higher interaction rate ν .

Generalizations of the above equations to $I > 2$ equivalent or several non-equivalent strategies are easily possible. In the latter case, superior strategies will tend to occur more frequently, but the polarization effect and the transi-

tion from individual to mass behavior can still occur under similar conditions as discussed above.

4 Decision Experiments for a Generalized Route Choice Scenario

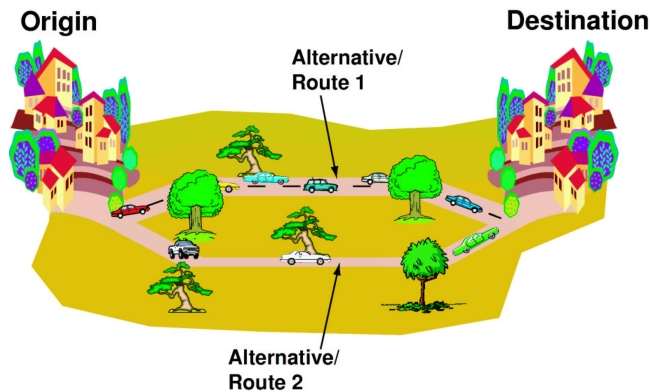

Fig. 7. Schematic illustration of the day-to-day route choice scenario (from [117]). Each day, the drivers have to decide between two alternative routes, 1 and 2. Note that, due to the different number of lanes, route 1 has a higher capacity than route 2. The latter is, therefore, used by less cars.

The coordinated and efficient distribution of limited resources by individual decisions is a fundamental and unsolved problem. When individuals compete for road capacities, time, space, money, etc., they normally take decisions based on aggregate rather than complete information, such as TV news or stock market indices. The resulting volatile decision dynamics and decision distribution are often far from being optimal. By means of experiments, we have identified ways of information presentation that can considerably improve the overall performance of the system. We also present a stochastic behavioral description allowing us to determine optimal strategies of decision guidance by means of user-specific recommendations. These strategies manage to increase the adaptability to changing returns (payoffs) and to reduce the deviation from the time-dependent user equilibrium, thereby enhancing the average and individual outcomes. Hence, our guidance strategies can increase the performance of all users by reducing overreaction and stabilizing the decision dynamics. Our results are significant for predicting decision behavior, for reaching optimal behavioral distributions by decision support systems, and for information service providers. One of the promising fields of application is traffic optimization.

Optimal route guidance strategies in overloaded traffic networks, for example, require reliable traffic forecasts (see Fig. 7). These are extremely difficult for two reasons: First of all, traffic dynamics is very complex, but after more than 50 years of research, it is relatively well understood [1]. The second and

more serious problem is the invalidation of forecasts by the driver reactions to route choice recommendations. Nevertheless, some keen scientists hope to solve this long-standing problem by means of an iteration scheme [34,98–105]: If the driver reaction was known from experiments [106–116], the resulting traffic situation could be calculated, yielding improved route choice recommendations, etc. Given this iteration scheme converges, it would facilitate optimal recommendations and reliable traffic forecasts anticipating the driver reactions. Based on empirically determined transition and compliance probabilities, the new procedure developed in the following would even allow us to reach the optimal traffic distribution in one single step and in harmony with the forecast.

Let us now quantify the success or payoff P_i of road users in terms of their inverse travel times. If one approximates the average vehicle speed V_i on route i by the linear relationship

$$V_i(n_i) = V_i^0 \left(1 - \frac{n_i(t)}{n_i^{\max}} \right), \quad (77)$$

the inverse travel times obey the payoff relations $P_i(n_i) = P_i^0 - P_i^1 n_i$ with

$$P_i^0 = \frac{V_i^0}{L_i} \quad \text{and} \quad P_i^1 = \frac{V_i^0}{n_i^{\max} L_i}. \quad (78)$$

Herein, V_i^0 denotes the maximum velocity (speed limit), n_i the number of drivers on route i , L_i its length, and n_i^{\max} its capacity, i.e. the maximum possible number of vehicles on route i . For an improved approach to determine the travel times in road networks see Ref. [118]. Note that alternative routes can reach comparable payoffs (inverse travel times) only when the total number $N(t)$ of vehicles is large enough to fulfil the relations $P_1(N(t)) < P_2(0) = P_2^0$ and $P_2(N(t)) < P_1(0) = P_1^0$. Our route choice experiment will address this traffic regime. Furthermore, we have the capacity restriction $N(t) < n_1^{\max} + n_2^{\max}$. $N(t) = n_1^{\max} + n_2^{\max}$ would correspond to a complete gridlock.

4.1 Experimental Setup and Previous Results

To determine the route choice behavior, Schreckenberg, Selten *et al.* [113] have recently carried out a decision experiment (see Fig. 8). N test persons had to repeatedly decide between two alternatives 1 and 2 (the routes) and should try to maximize their resulting payoffs (describing something like the speeds or inverse travel times). To reflect the competition for a limited resource (the road capacity), the received payoffs

$$P_1(n_1) = P_1^0 - P_1^1 n_1 \quad \text{and} \quad P_2(n_2) = P_2^0 - P_2^1 n_2 \quad (79)$$

went down with the numbers of test persons n_1 and $n_2 = N - n_1$ deciding for alternatives 1 and 2, respectively. The *user equilibrium* corresponding to equal payoffs for both alternative decisions is found for a fraction

$$f_1^{\text{eq}} = \frac{n_1}{N} = \frac{P_2^1}{P_1^1 + P_2^1} + \frac{1}{N} \frac{P_1^0 - P_2^0}{P_1^1 + P_2^1} \quad (80)$$

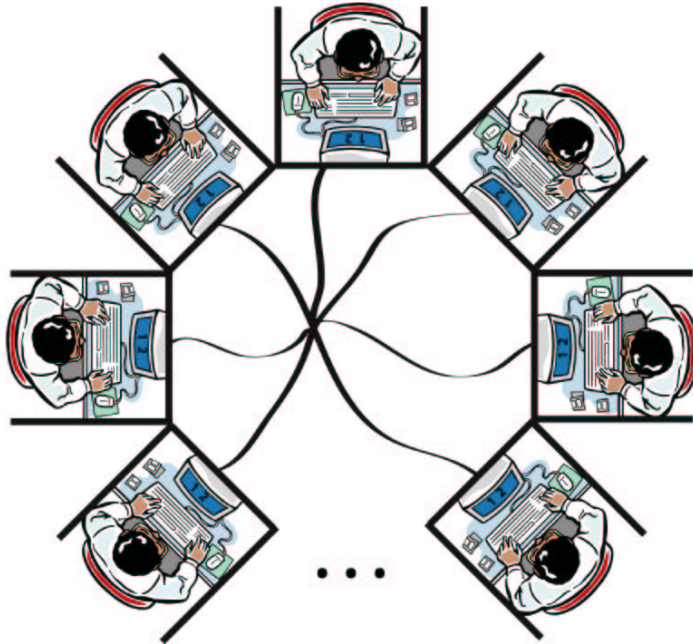

Fig. 8. Schematic illustration of the decision experiment (from [117]). Several test persons take decisions based on the aggregate information their computer displays. The computers are connected and can, therefore, exchange information. However, a direct communication among players is suppressed.

of persons choosing alternative 1. The *system optimum* corresponds to the maximum of the total payoff $n_1 P_1(n_1) + n_2 P_2(n_2)$, which lies by an amount of

$$\frac{1}{2N} \frac{P_1^0 - P_2^0}{P_1^1 + P_2^1} \quad (81)$$

below the user optimum. Therefore, only experiments with a few players allow to find out, whether the test persons adapt to the user or the system optimum. Small groups are also more suitable for the experimental investigation of the fluctuations in the system and of the long-term adaptation behavior. Schreckenberg, Selten *et al.* found that, on average, the test groups adapted relatively well to the user equilibrium. However, although it appears reasonable to stick to the same decision once the equilibrium is reached, the standard deviation stayed at a finite level. This was not only observed in “*treatment*” 1, where all players knew only their own (previously experienced) payoff, but also in *treatment* 2, where the payoffs $P_1(n_1)$ and $P_2(n_2)$ for both, 1- and 2-decisions, were transmitted to all players (analogous to radio news). Nevertheless, *treatment* 2 could decrease the changing rate and increase the average payoffs (cf. Fig. 9). For details regarding the statistical analysis see Ref. [113].

To explain the mysterious persistence in the changing behavior and explore possibilities to suppress it, we have repeated these experiments with more iterations and tested additional treatments. In the beginning, all treatments were

consecutively applied to the same players in order to determine the response to different kinds of information (see Fig. 9). Afterwards, single treatments and variants of them have been repeatedly tested with different players to check our conclusions. Apart from this, we have generalized the experimental setup in the sense that it was not anymore restricted to route choice decisions: The test persons did not have any idea of the payoff functions in the beginning, but had to develop their own hypothesis about them. In particular, the players did not know that the payoff decreased with the number of persons deciding for the same alternative.

In *treatment 3*, every test person was informed about the own payoff $P_1(n_1)$ [or $P_2(n_2)$] and the *potential payoff*

$$P_2(N - n_1 + \epsilon N) = P_2(n_2) - \epsilon N P_2^1 \quad (82)$$

[or $P_1(N - n_2 + \epsilon N) = P_1(n_1) - \epsilon N P_1^1$] he or she would have obtained, if a fraction ϵ of persons had additionally chosen the other alternative (here: $\epsilon = 1/N$). Treatments 4 and 5 were variants of treatment 3, but some payoff parameters were changed in time to simulate varying environmental conditions. In *treatment 5*, each player additionally received an individual recommendation which alternative to choose.

The higher changing rate in treatment 1 compared to treatment 2 can be understood as effect of an exploration rate ν_1 required to find out which alternative performs better. It is also plausible that treatment 3 could further reduce the changing rate: In the user equilibrium with $P_1(n_1) = P_2(n_2)$, every player knew that he or she would *not* get *the same*, but a *reduced* payoff, if he or she would change the decision. That explains why the new treatment 3 could reach a great adaptation performance, reflected by a very low standard deviation and almost optimal average payoffs. The behavioral changes induced by the treatments were not only observed on average, but for all single individuals (see Fig. 10). Moreover, even the smallest individual cumulative payoff exceeded the highest one in treatment 1. Therefore, treatment 3's way of information presentation is much superior to the ones used today.

4.2 Is it Just an Unstable User Equilibrium?

In this section, we will investigate why players changed their decision in the user equilibrium at all. With $P_1(1, t) = \langle n_1(t) \rangle / N$ and $\langle n_i(t) \rangle = n_i(t)$ (as $n_i(t)$ are the *measured* numbers of i -decisions at time t), we find the following balance equation for the decision experiment:

$$\langle n_1(t+1) \rangle - n_1(t) = p(1|2, n_1; t) n_2(t) - p(2|1, n_1; t) n_1(t). \quad (83)$$

Assuming stationary transition probabilities $p(2|1, n_1)$ (after a transient phase), the equilibrium distribution corresponds to

$$\langle n_1(t+1) \rangle = \langle n_1(t) \rangle = n_1(t). \quad (84)$$

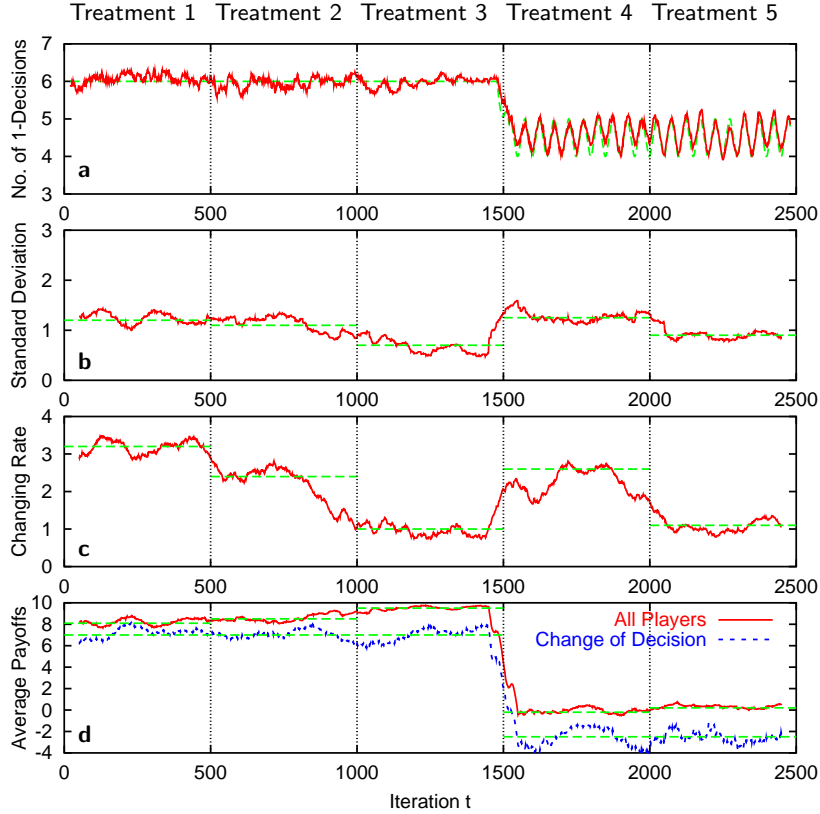

Fig. 9. Overview of treatments 1 to 5 [117] (with $N = 9$ and payoff parameters $P_2^0 = 28$, $P_1^1 = 4$, $P_2^1 = 6$, and $P_1^0 = 34$ for $0 \leq t \leq 1500$, but a zick-zack-like variation between $P_1^0 = 44$ and $P_1^0 = -6$ with a period of 50 for $1501 \leq t \leq 2500$): **(a)** Average number of decisions for alternative 1 (solid line) compared to the user equilibrium (broken line), **(b)** standard deviation of the number of 1-decisions from the user equilibrium, **(c)** number of decision changes from one iteration to the next one, **(d)** average payoff per iteration for players who have changed their decision and for all players. The latter increased with a reduction in the changing rate, but normally stayed below the payoff in the user equilibrium (which is 1 on average in treatments 4 and 5, otherwise 10). The displayed moving time-averages [(a) over 40 iterations, (b)-(d) over 100 iterations] illustrate the systematic response to changes in the treatment every 500 iterations. Dashed lines in (b)-(d) show estimates of the stationary values after the transient period (to guide the eyes), while time periods around the dotted lines are not significant. Compared to treatment 1, treatment 3 managed to reduce the changing rate and to increase the average payoffs (three times more than treatment 2 did). These changes were systematic for *all* players (see Fig. 10). In treatment 4, the changing rate and the standard deviation went up, since the user equilibrium changed in time. The user-specific recommendations in treatment 5 could almost fully compensate for this. The above conclusions are also supported by additional experiments with single treatments.

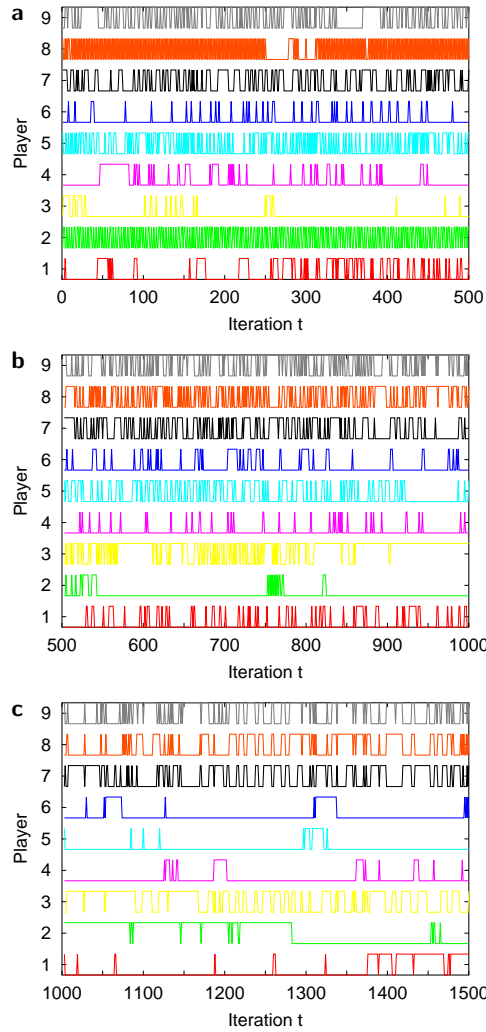

Fig. 10. Comparison of the individual decision behaviors in **(a)** treatment 1, **(b)** treatment 2, and **(c)** treatment 3 (from [117]). The upper values correspond to a decision for alternative 2, the lower ones for alternative 1. Note that some test persons showed similar behaviors (either more or less the same or almost opposite ones), although they could not talk to each other. This shows that there are some typical strategies how to react to a certain information configuration, i.e. to a certain decision distribution. The group has, in fact, to develop complementary strategies in order to reach a good adaptation performance. Identical strategies would perform poorly (as in the minority game [5–7]). Despite the mentioned complementary behavior, there is a characteristic reaction to changes in the treatment. For example, compared to treatment 2 all players reduce their changing rate in treatment 3.

Consequently, the equilibrium condition

$$p(2|1, n_1)n_1(t) = p(1|2, n_1)n_2(t) \quad (85)$$

should be fulfilled for the user equilibrium $n_1(t) = f_1^{\text{eq}}N$ and $n_2(t) = (1 - f_1^{\text{eq}})N$. This, however, is generally *not* compatible with the assumption

$$p(2|1, n_1) \propto \exp[P_2(N - n_1 + 1) - P_1(n_1)] \quad (86)$$

or similar specifications of the transition probability that increase monotonically with the payoff P_2 or the payoff difference $P_2 - P_1$! Since normally

$$\frac{p(2|1, f_1^{\text{eq}}N)}{p(1|2, f_1^{\text{eq}}N)} \neq \frac{1 - f_1^{\text{eq}}}{f_1^{\text{eq}}}, \quad (87)$$

the test persons would have serious problems reaching the user equilibrium. The decision distribution would possibly tend to oscillate around it, corresponding to an unstable user equilibrium.

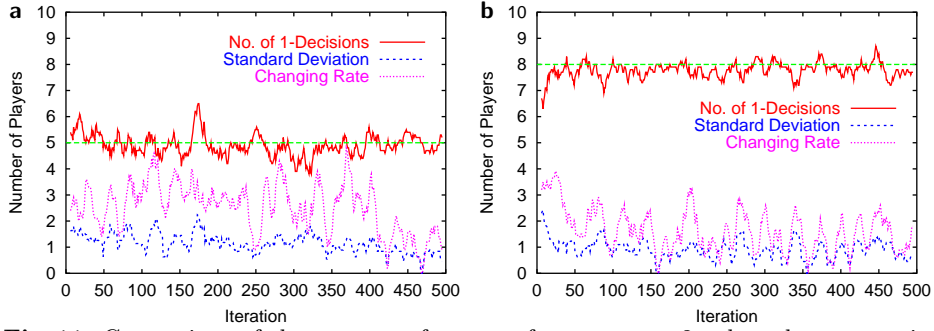

Fig. 11. Comparison of the group performance for treatment 2, when the user equilibrium corresponds to **(a)** $f_1^{\text{eq}} = 50\%$ 1-decisions (for $P_1^0 = 32$, $P_1^1 = 5$, $P_2^0 = 32$, $P_2^1 = 5$) or **(b)** $f_1^{\text{eq}} = 80\%$ 1-decisions (for $P_1^0 = 42$, $P_1^1 = 4$, $P_2^0 = 22$, $P_2^1 = 6$). If the user equilibrium were unstable for $f_1^{\text{eq}} \neq 1/2$, the changing rate and standard deviation should be lower in **(a)** than in **(b)**. The observation contradicts this assumption. The persistent changing rate is also not caused by a difference between the system and the user optimum, since this is zero in **(a)** but one in **(b)**. Instead, the higher changing rate for the symmetrical case $f_1^{\text{eq}} = 1/2$ is for statistical reasons. (Remember that the variance of a binomial distribution $B(N, p)$ is $Np(1 - p)$ and becomes maximal for $p = 1/2$.)

We have tested this potential interpretation of the on-going tendency to change the decision. Figure 11 compares the changing rates and the standard deviations for a case where the equilibrium condition (85) should be valid and another case where it should be violated. However, the changing rate and standard deviation were higher in the first case, so that the hypothesis of an unstable equilibrium must be wrong. In the user equilibrium with $n_1(t) = f_1^{\text{eq}}N = N - n_2(t)$,

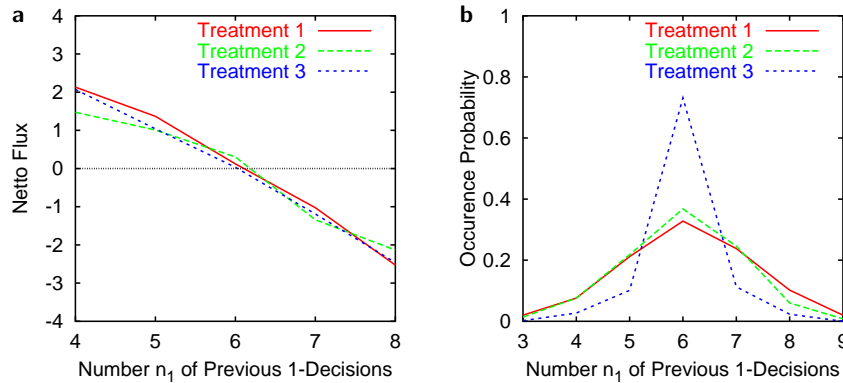

Fig. 12. (a) The netto flux $p(1|2, n_1)n_2(t) - p(1|2, n_1)n_1(t)$, which reflects the systematic part of decision changes, does not significantly depend on the treatment. As expected, it is zero in the user equilibrium, positive below it, and negative above it. **(b)** The treatment can influence the occurrence probability of decision distributions. Compared to treatments 1 and 2, the probability distribution is much more sharply peaked for treatment 3, implying a significantly smaller level of randomness during decision changes (a smaller “diffusion coefficient”).

the inflow $p(1|2, n_1)n_2(t)$ is, in fact, well balanced by the outflow $p(1|2, n_1)n_1(t)$, as Figure 12 shows. By the way, the results displayed in Fig. 11 also disprove the idea that a difference between the user and the system optimum may be the reason for the continuing changing behavior.

4.3 Explaining the Volatile Decision Dynamics

The reason for the pertaining changing behavior can be revealed by a more detailed analysis of the individual decisions in treatment 3. Figure 13 shows some kind of intermittent behavior, i.e. quiescent periods without changes, followed by turbulent periods with many changes. This is reminiscent of volatility clustering in stock market indices [121–123], where individuals also react to aggregate information reflecting all decisions (the trading transactions). Single players seem to change their decision to reach above-average payoffs. In fact, although the cumulative individual payoff is anticorrelated with the average changing rate, some players receive higher payoffs with larger changing rates than others. They profit from the overreaction in the system. Once the system is out of equilibrium, all players respond in one way or another. Typically, there are too many decision changes (see Figs. 13 and 15). The corresponding overcompensation, which had also been predicted by computer simulations [99,102–104,111,124], gives rise to “turbulent” periods.

Finally, we note that the calm periods without decision changes tend to become longer in the course of time. That is, after a very long time period the individuals seem to learn not to change their behavior when the user equilibrium is reached. This is not only found in Fig. 13, but also visible in Fig. 9c after about 800 iterations. In larger systems (with more test persons) this transient period

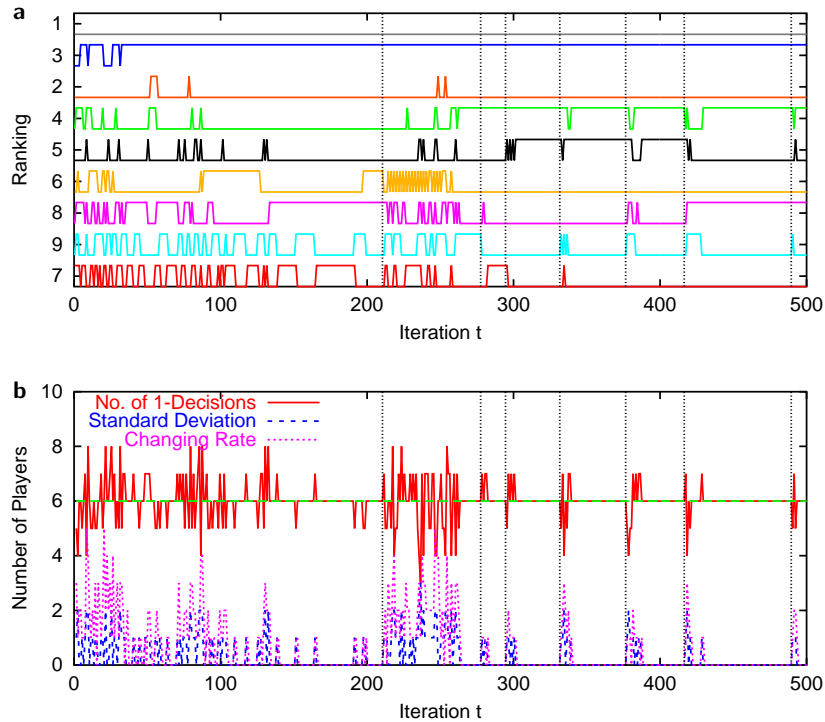

Fig. 13. Illustration of typical results for treatment 3 [117] (which was here the only treatment applied to the test persons, in contrast to Fig. 9). **(a)** Decisions of all 9 players. Players are displayed from the top to the bottom in the order of increasing changing rate. Although the ranking of the cumulative payoff and the changing rate are anticorrelated, the relation is not monotonic. Note that turbulent or volatile periods characterized by many decision changes are usually triggered by individual changes after quiescent periods (dotted lines). **(b)** The changing rate is mostly larger than the (standard) deviation from the user equilibrium $n_1 = f_1^{\text{eq}}N = 6$, indicating an overreaction in the system.

would take even longer, so that this stabilization effect could not be observed by Schreckenberg, Selten *et al.* [113].

5 Simulation of Reinforcement Learning and Emergence of Individual Response Patterns

A close look at Fig. 14a reveals additional details of decision behavior:

- Some players change their decision more frequently than others and
- some test persons show similar behaviors (e.g., players 8 and 9 or 1 and 7 for $t \geq 400$), while some display almost opposite behaviors (e.g., players 7 and 8).

The second point is very surprising, as the players could not communicate with each other. However, both observations can be explained by the conjecture that the individuals develop different characteristic strategies how to react to specific information. “Movers” and “stayers” or direct and contrary strategies have, in fact, been observed by Schreckenberg, Selten *et al.* [113], and it is an interesting question, how they arise. The group has to develop complementary strategies in order to reach a good adaptation performance. As a consequence, if some players do not react to changing conditions, others will take the chance to earn additional payoff. This experimentally supports the behavior assumed in the theory of efficient markets. Note that identical strategies would perform poorly, as in the minority game [4–7].

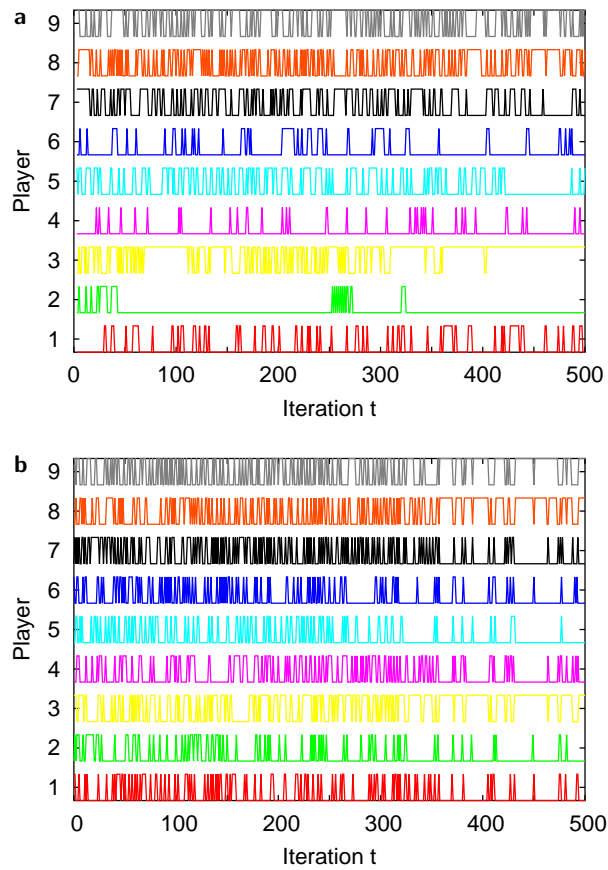

Fig. 14. (a) Typical individual decision changes of 9 test persons exposed to treatment 2 with the parameters specified in Fig. 9. **(b)** Simulation of decision changes based on a model of reinforcement learning (see main text) with parameter values $\delta = 0.01$, $q_0 = 0.4$, and $r = 0.995$.

In order to reproduce the above described evolution of complementary strategies and other observed features, we have developed a simulation model based on reinforcement learning [119,120]. At first, it appears reasonable to apply a learning strategy that reproduces the ‘law of relative effect’, according to which the probability $p'_\alpha(i, t+1)$ of an individual α to choose alternative i at time $t+1$ would reflect the relative frequency with which this alternative was successful in the past. This can, for example, be reached by means of the reinforcement rule

$$p'_\alpha(i, t+1) = \begin{cases} 1 - q_0[1 - p'_\alpha(i, t)] & \text{in case of a successful decision} \\ q_0 p'_\alpha(i, t) & \text{otherwise} \end{cases} \quad (88)$$

[120], where the way in which a successful decision is defined may vary from one situation to another. However, a probabilistic decision strategy, when applied by all individuals, produces a large amount of stochastic fluctuations, i.e. the user equilibrium is hard to maintain. More importantly, although the above learning strategy may explain a specialization in the individual behaviors (i.e. different decision probabilities, depending on the respective success history), it does not allow to understand the state-dependent probability of decision changes (see Fig. 18). We will, therefore, develop a model for the conditional (transition) probability $p_\alpha(i|i', n_1; t)$ of individual α to select alternative i , given that the previous decision was i' and n_1 individuals had taken decision 1. Furthermore, let us assume that each individual updates this transition probability according to the following scheme:

$$p_\alpha(i|i', n_1; t+1) = \begin{cases} \max[1 - \delta, p_\alpha(i|i', n_1; t) + q(t+1)] & \text{for a successful decision,} \\ \min[\delta, p_\alpha(i|i', n_1; t) - q(t+1)] & \text{otherwise.} \end{cases} \quad (89)$$

Due to the normalization of transition probabilities, we have the additional relation

$$p_\alpha(3 - i|i', n_1; t+1) = 1 - p_\alpha(i|i', n_1; t+1), \quad (90)$$

as $3 - i$ is the alternative of decision $i \in \{1, 2\}$. The parameter $\delta \approx 0$ reflects a minimum changing probability, which ensures that there is always a certain readiness to adapt to a potentially changing environment. It is responsible for the stochastic termination of quiescent phases, in which nobody changes the decision. Our simulations were run with $\delta = 0.01$, i.e. the minimum changing probability was assumed to be 1 percent.

The parameter $q(t)$ denotes the size of the adaptation step, by which the transition probability is increased in case of success or otherwise decreased, while the minimum and maximum functions guarantee that the transition probabilities $p_\alpha(i|i', n_1; t+1)$ stay between the minimum value δ and the maximum value $1 - \delta$. A time-dependent choice such as

$$q(t) = q_0 r^t \quad (91)$$

with an initial value q_0 of q ($0 < q_0 < 1$) and a value of r slightly smaller than 1 allow one to describe that the learning rate is large in the beginning, when the different possible strategies are explored, but it eventually goes down,

as the optimum strategy becomes more and more clear. In the course of time, this leads to the stabilization of a particular, history-dependent response pattern that characterizes the individual decision strategy. The resulting response pattern shows either a high likelihood to stay with the previous decision (with $p_\alpha \approx \delta$) or a high likelihood to change it (with $p_\alpha \approx 1 - \delta$), depending on the respective system state n_1 and previous decision i' . That is, the resulting strategy tends to be approximately deterministic, reflecting that the individual believes to know what is the ‘right’ decision. This is markedly different from other decision models with reinforcement learning [119,120]. Nevertheless, when averaging over all occurring system states, the individuals appear to play mixed strategies, i.e. they seem to show probabilistic (rather than almost deterministic) decision behavior (see Fig. 18). Therefore, our approach is expected to be consistent with the law of relative effect, but only in the statistical sense. Altogether, formula (91) reflects the observed trial-and-error behavior in the beginning (the ‘experimentation phase’), but a tendency to follow learned strategies later on without significant changes. The parameters δ , q_0 , and r may, of course, be individual, but for reasons of simplicity we have assumed identical values in our simulations.

The way, in which a successful decision is defined, may depend on the respective situation or experiment. In our simulations of treatment 2, we have assumed that the decision is valued as successful, when

$$P_i(n_i(t+1)) \geq P_{3-i}(N - n_i(t+1)) = P_{3-i}(n_{3-i}(t+1)) \quad (92)$$

and

$$P_i(n_i(t+1)) \geq P_{i'}(n_{i'}(t)), \quad (93)$$

i.e. when the payoff was at least as large as for the other alternative $3-i$ and not smaller than in the previous time step. The first decision was made randomly with probability 1/2. The following decisions were also randomly chosen, but in accordance with the respective transition probabilities, which were updated according to the above scheme.

The simulation results are in good qualitative agreement with the features observed in our experiments. We find an adaptation of the group to the user equilibrium with an average individual payoff of approximately 8.5, as in our experiments. Moreover, the changing rate is high in the beginning and decreases in the course of time (see Fig. 14b). As experimentally observed, some players change their decision more frequently than others, and we find almost similar or opposite behaviors after some time. That is, our simulations allow to reproduce that players develop individual strategies (i.e. response patterns, “roles”, or “characters”) in favour of a good group performance.

By means of our simulations, we can not only reproduce the main experimental observations. One can also optimize the group sizes and number of iterations of decision experiments. The above simulation concept is now used to design new experiments, which try to improve the system performance or even to establish the social optimum by particular information strategies. In the following section, we will, for example, introduce a possible concept for decision guidance.

5.1 Potentials and Limitations of “Decision Control”

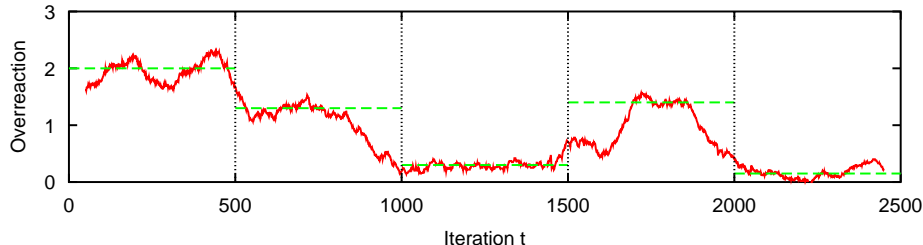

Fig. 15. Measured overreaction, i.e., difference between the actual number of decision changes (the changing rate) and the required one (the standard deviation) [117]. The overreaction can be significantly influenced by the treatment, i.e. the way of information presentation. The minimum overreaction was reached by treatment 5, i.e. user-specific recommendations.

To avoid overreaction, in treatment 5 we have recommended a number $f_1^{\text{eq}}(t+1)N - n_1(t)$ of players to change their decision and the other ones to keep it. These user-specific recommendations helped the players to reach the smallest overreaction of all treatments (see Fig. 15) and a very low standard deviation, although the payoffs were changing in time (see Fig. 16). Treatment 4 shows how the group performance was affected by the time-dependent user equilibrium: Even without recommendations, the group managed to adapt to the changing conditions surprisingly well, but the standard deviation and changing rate were approximately as high as in treatment 2 (see Fig. 9). This adaptability (the collective “group intelligence”) is based on complementary responses (direct and contrary ones [113], “movers” and “stayers”, cf. Fig. 10). That is, if some players do not react to the changing conditions, others will take the chance to earn additional payoff. This experimentally supports the behavior assumed in the theory of efficient markets, but here the efficiency is limited by overreaction.

In most experiments, we found a constant and high compliance $C_S(t) \approx 0.92$ with recommendations to stay, but the compliance $C_M(t)$ with recommendations to change (to ‘move’) [109,110,125,126] turned out to vary in time. It decreased with the reliability of the recommendations (see Fig. 17a), which again dropped with the compliance.

Based on this knowledge, we have developed a model, how the competition for limited resources (such as road capacity) could be *optimally* guided by means of information services. Let us assume we had $n_1(t)$ 1-decisions at time t , but the optimal number of 1-decision at time $t+1$ is calculated to be $f_1^{\text{eq}}(t+1)N \geq n_1(t)$. Our aim is to balance the deviation $f_1^{\text{eq}}(t+1)N - n_1(t) \geq 0$ by the expected net number

$$\langle \Delta n_1(t+1) \rangle = \langle n_1(t+1) - n_1(t) \rangle = \langle n_1(t+1) \rangle - n_1(t) \quad (94)$$

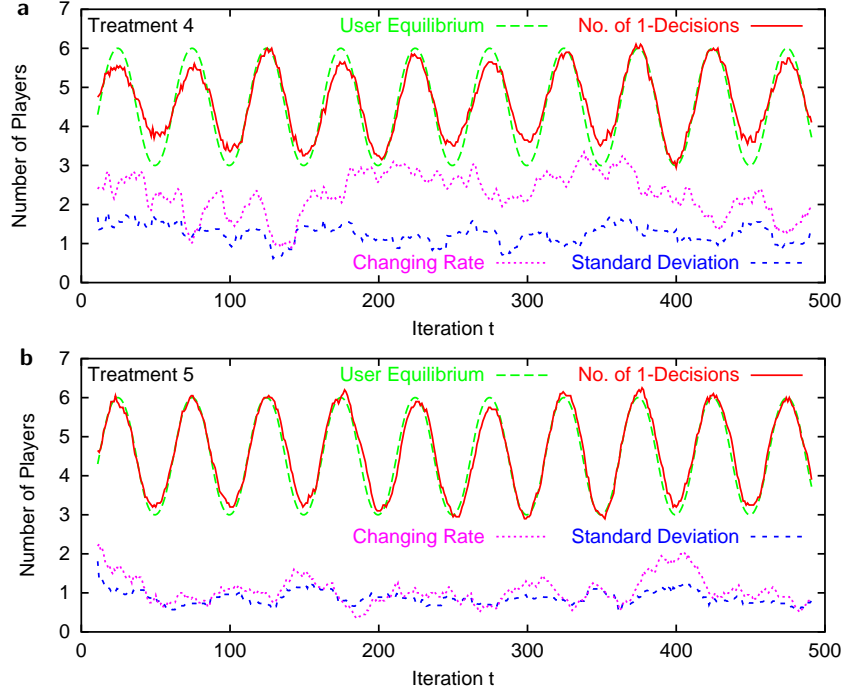

Fig. 16. Representative examples for **(a)** treatment 4 and **(b)** treatment 5 (from [117]). The displayed curves are moving time-averages over 20 iterations. Compared to treatment 4, the user-specific recommendations in treatment 5 (assuming $C_M = C_S = 1$, $R_1 = 0$, $R_2 = \max([f_1^{\text{eq}}(t+1)N - n_1(t) + B(t+1)]/n_2(t), 1)$, $I_1 = I_2 = 1$) could increase the group adaptability to the user equilibrium a lot, even if they had a systematic or random bias B (see Fig. 17a). The standard deviation was reduced considerably and the changing rate even more.

of transitions from decision 2 to decision 1, i.e. $f_1^{\text{eq}}(t+1)N - n_1(t) = \langle \Delta n_1(t+1) \rangle$. In the case $f_1^{\text{eq}}(t+1)N - n_1(t) < 0$, indices 1 and 2 have to be interchanged.

Let us assume we give recommendations to fractions $I_1(t)$ and $I_2(t)$ of players who had chosen decision 1 and 2, respectively. The fraction of changing recommendations to previous 1-choosers shall be denoted by $R_1(t)$, and for previous 2-choosers by $R_2(t)$. Correspondingly, fractions of $[1 - R_1(t)]$ and $[1 - R_2(t)]$ receive a recommendation to stick to the previous decision. Moreover, $[1 - C_M(t)]$ is the *refusal probability* of recommendations to change, while $[1 - C_S(t)]$ is the refusal probability of recommendations to stay. Finally, we denote the spontaneous transition probability from decision 1 to 2 by $p_a(2|1, n_1; t)$ and the inverse transition probability by $p_a(1|2, n_1; t)$, in case a player does not receive any recommendation. This happens with probabilities $[1 - I_1(t)]$ and $[1 - I_2(t)]$, respectively. Both transition probabilities $p_a(2|1, n_1; t)$ and $p_a(1|2, n_1; t)$ are functions of the number $n_1(t) = N - n_2(t)$ of previous 1-decisions. The index a allows us to reflect different strategies or characters of players. The fraction of players

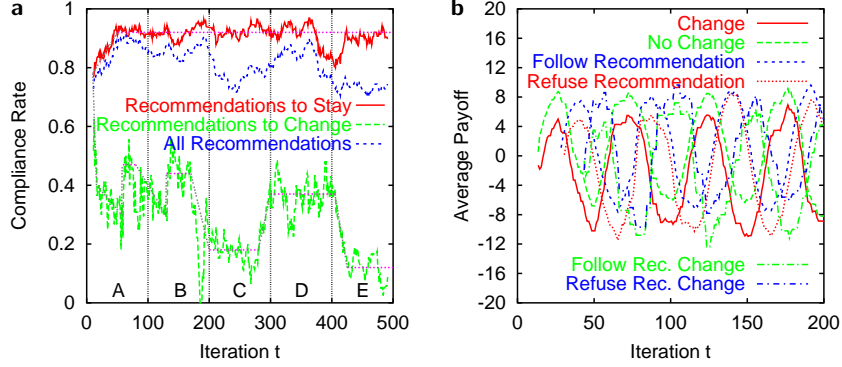

Fig. 17. (a) In treatment 5, the compliance to recommendations to change dropped considerably below the compliance to recommendations to stay. The compliance to changing recommendations was very sensitive to the degree of their reliability, i.e. participants followed recommendations just as much as they helped them to reach the user equilibrium (so that the bias B did not affect the small deviation from it, see Fig. 16b). While during time interval **A**, the recommendations would have been perfect, if all players had followed them, in time interval **B** the user equilibrium was overestimated by $B = +1$, in **C** it was underestimated by $B = -2$, in **D** it was randomly over- or underestimated by $B = \pm 1$, and in **E** by $B = \pm 2$. Obviously, a random error is more serious than a systematic one of the same amplitude. Dotted non-vertical lines illustrate the estimated compliance levels during the transient periods and afterwards (horizontal dotted lines). **(b)** The average payoffs varied largely with the decision behavior. Players who changed their decision got significantly lower payoffs on average than those who kept their previous decision. Even recommendations could not overcome this difference: It stayed profitable not to change, although it was generally better to follow recommendations than to refuse them. For illustrative reasons, the third and fourth line were shifted by 15, while the fifth and sixth line were shifted by 30 iterations. (From [117].)

pursuing strategy a is then denoted by $F_a(t)$. Applying methods summarized in Ref. [18,19], the expected change $\langle \Delta n_1(t+1) \rangle$ of n_1 is given by the balance equation

$$\begin{aligned}
 \langle \Delta n_1(t+1) \rangle &= \sum_a p_a(1|2, n_1; t) F_a(t) [1 - I_2(t)] n_2(t) \\
 &\quad - \sum_a p_a(2|1, n_1; t) F_a(t) [1 - I_1(t)] n_1(t) \\
 &\quad + \sum_a \{C_M^a(t) R_2(t) + [1 - C_S^a(t)] [1 - R_2(t)]\} F_a(t) I_2(t) n_2(t) \\
 &\quad - \sum_a \{C_M^a(t) R_1(t) + [1 - C_S^a(t)] [1 - R_1(t)]\} F_a(t) I_1(t) n_1(t), \quad (95)
 \end{aligned}$$

which should agree with $f_1^{\text{eq}}(t+1)N - n_1(t)$. We have evaluated the overall transition probabilities

$$p(1|2, n_1; t) = \sum_a p_a(1|2, n_1; t)F_a(t) \quad \text{and} \quad p(2|1, n_1; t) = \sum_a p_a(2|1, n_1; t)F_a(t). \quad (96)$$

According to classical decision theories [13,14,18,19,127], we would expect that the transition probabilities $p_a(2|1, n_1; t)$ and $p(2|1, n_1; t)$ should be monotonically increasing functions of the payoff $P_2(N - n_1(t))$, the payoff difference $P_2(N - n_1(t)) - P_1(n_1(t))$, the potential payoff $P_2(N - n_1(t) + \epsilon N)$, or the potential payoff gain $P_2(N - n_1(t) + \epsilon N) - P_1(n_1(t))$. All these quantities vary linearly with n_1 , so that $p(2|1, n_1; t)$ should be a monotonic function of $n_1(t)$. A similar thing should apply to $p(1|2, n_1; t)$. Instead, the experimental data point to transition probabilities with a *minimum* at the user equilibrium (see Fig. 18a). That is, the players stick to a certain alternative for a longer time, when the system is close to the user equilibrium. This is a result of learning [128–133]. In fact, we find a gradual change of the transition probabilities in time (see Fig. 18b). The corresponding “learning curves” reflect the players’ adaptation to the user equilibrium.

After the experimental determination of the transition probabilities $p(2|1, n_1; t)$, $p(1|2, n_1; t)$ and specification of the overall compliance probabilities

$$C_M(t) = \sum_a C_M^a(t)F_a(t), \quad C_S(t) = \sum_a C_S^a(t)F_a(t), \quad (97)$$

we can guide the decision behavior in the system via the levels $I_i(t)$ of information dissemination and the fractions $R_i(t)$ of recommendations to change ($i \in \{1, 2\}$). These four degrees of freedom allow us to apply a variety of guidance strategies depending on the respective information medium. For example, a guidance by radio news is limited by the fact that $I_1(t) = I_2(t)$ is given by the average percentage of radio users. Therefore, equation (95) cannot always be solved by variation of the fractions of changing recommendations $R_i(t)$. User-specific services have much higher guidance potentials and could, for example, be transmitted via SMS. Among the different guidance strategies fulfilling equation (95), the one with the minimal statistical variance will be the best. However, it would already improve the present situation to inform everyone about the *fractions* $R_i(t)$ of participants who should change their decision, as users can learn to respond with varying frequencies (see Fig. 18). Some actually respond more sensitively than others (see Fig. 10), so that a group of users can reach a good overall performance based on individual strategies.

The outlined guidance strategy could, of course, also be applied to reach the system optimum rather than the user optimum. The values of $\Delta n_1(t+1)$ would just be different. Note, however, that the users would soon recognize that this guidance is not suitable to reach the user optimum. Consequently, the compliance probabilities would gradually go down, which would affect the potentials and reliability of the guidance system.

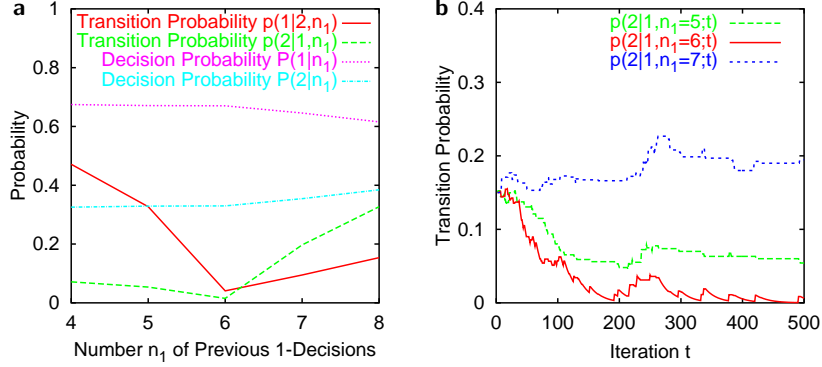

Fig. 18. Illustration of group-averaged decision distributions $P(i|n_1)$ and transition probabilities $p(i'|i, n_1; t)$ measured in treatment 3 (from [117]). **(a)** The probability $P(1|n_1)$ to choose alternative 1 was approximately $2/3$, independently of the number n_1 of players who had previously chosen alternative 1. The probability $P(2|n_1)$ to choose alternative 2, given that n_1 players had chosen alternative 1, was always about $1/3$. In contrast, the group-averaged transition probability $p(1|2, n_1)$ describing decision changes from alternative 2 to 1 did depend on the number n_1 of players who had chosen decision 1. The same was true for the inverse transition probability $p(2|1, n_1)$ from decision 1 to decision 2. Remarkably enough, these transition probabilities are not monotonically increasing with the payoff or the expected payoff gain, as they do not monotonically increase with n_1 . Instead, the probability to change the decision shows a minimum at the user equilibrium $n_1 = f_1^{\text{eq}} N = 6$. Figures 10 and 14 suggest that this transition probability does not reflect the individual transition probabilities. There rather seem to be typical response patterns (see Sec. 5), i.e. some individuals react only to large deviations from the user equilibrium, while others already react to small ones, so that the overall response of the group reaches a good adaptation performance. **(b)** The reason for the different transition probabilities is an adaptation process in which the participants learn to take fewer changing decisions, when the user equilibrium is reached or close by, but more, when the user equilibrium is far away. (The curves were exponentially smoothed with $\alpha = 0.05$.)

In practical applications, we would determine the compliance probabilities $C_j(t)$ with $j \in \{M, S\}$ (and the transition probabilities) on-line with an exponential smoothing procedure according to

$$C_j(t+1) = \alpha C'_j(t) + (1 - \alpha) C_j(t) \quad \text{with} \quad \alpha \approx 0.1, \quad (98)$$

where $C'_j(t)$ is the percentage of participants who have followed their recommendation at time t . As the average payoff for decision changes is normally lower than for staying with the previous decision (see Figs. 17 and 9d), a high compliance probability C_M is hard to achieve. That is, individuals who follow recommendations to change normally pay for reaching the user equilibrium (because of the overreaction in the system). Hence, there are no good preconditions to charge the players for recommendations, as we did in another treatment. Consequently, only a few players requested recommendations, which reduced their reliability, so that the overall performance of the system went down.

5.2 Master Equation Description of Iterated Decisions

The description of decisions that are taken at discrete time steps (e.g. on a day-to-day basis) is different from decisions in continuous time. We can, however, apply the time-discrete master equation (30) with $\Delta t = 1$, if there is no need to distinguish several characters a . As the number of individuals changing to the other alternative is given by a *binomial distribution*, we obtain the following expression for the configurational transition probability to be inserted into Eq. (30):

$$\begin{aligned}
 & P((n_1, n_2), t + 1 \mid (n_1 - \Delta n_1, n_2 + \Delta n_1), t) \\
 &= \sum_{k=0}^{\min(n_1 - \Delta n_1, n_2)} \binom{n_2 + \Delta n_1}{\Delta n_1 + k} p(1|2, n_1 - \Delta n_1; t)^{\Delta n_1 + k} [1 - p(1|2, n_1 - \Delta n_1; t)]^{n_2 - k} \\
 & \quad \times \binom{n_1 - \Delta n_1}{k} p(2|1, n_1 - \Delta n_1; t)^k [1 - p(2|1, n_1 - \Delta n_1; t)]^{n_1 - \Delta n_1 - k}. \quad (99)
 \end{aligned}$$

This formula sums up the probabilities that $\Delta n_1 + k$ of $n_2 + \Delta n_1$ previous 2-choosers change independently to alternative 1 with probability $p(1|2, n_1 - \Delta n_1; t)$, while k of the $n_1 - \Delta n_1$ previous 1-choosers change to alternative 2 with probability $p(2|1, n_1 - \Delta n_1; t)$, so that the net number of changes is Δn_1 . If $\Delta n_1 < 0$, the roles of alternatives 1 and 2 have to be interchanged. Only in the limits $p(1|2, n_1 - \Delta n_1; t) \approx 0$ and $p(2|1, n_1 - \Delta n_1; t) \approx 0$ corresponding to $\Delta t \approx 0$ do we get the approximation

$$\begin{aligned}
 & P((n_1, n_2), t + 1 \mid (n_1 - \Delta n_1, n_2 + \Delta n_1), t) \\
 & \approx \begin{cases} p(1|2, n_1 - 1; t)(n_2 + 1) & \text{if } \Delta n_1 = +1 \\ p(2|1, n_1 + 1; t)(n_1 + 1) & \text{if } \Delta n_1 = -1 \\ 0 & \text{otherwise,} \end{cases} \quad (100)
 \end{aligned}$$

which is relevant for the time-continuous master equation.

The potential use of Eq. (99) is the calculation of the statistical variation of the decision distribution or, equivalently, the number n_1 of 1-choosers. It also allows one to determine the variance, which the optimal guidance strategy should minimize in favour of reliable recommendations.

6 Summary and Outlook

In the first sections of this contribution, we tried to develop a consistent theory of decision behavior. We started from socio-psychological observations regarding single decision-making processes and concluded that decisions can be interpreted as phase transitions. Moreover, a transitive preference scale was found to be restricted to particular situations. Our probabilistic approach improves the concept of *homo economicus*, as it takes into account limited or uncertain information, limited processing capabilities (e.g. incomplete decisions), and emotional aspects

of decision-making. We have also considered non-linear interactions among individuals, which allowed us to understand polarized decision behavior (in particular regarding emotionally loaded issues), the self-organization of behavioral conventions, and the transition from individual to mass behavior. Several fields of application have been outlined, such as opinion formation, fashion cycles, social force models, logistic and gravity models, or dynamical game theory, which have all been special cases of the developed dynamical decision theory.

With the finally described decision experiments, we have explored different and identified superior ways of information presentation that facilitate to guide user decisions in the spirit of higher payoffs. By far the least standard deviations from the user equilibrium could be reached by presenting the own payoff and the potential payoff, if the respective participant (or a certain fraction of players) had additionally chosen the other alternative. Interestingly, the decision dynamics was found to be intermittent similar to the volatility clustering in stock markets, where individuals also react to aggregate information. This results from the desire to reach above-average payoffs, combined with the immanent overreaction in the system. We have also demonstrated that payoff losses due to a volatile decision dynamics (e.g., excess travel times) can be reduced via user-specific recommendations by a factor of three or more. Such kinds of results will be applied to the route guidance on German highways (see, for example, the project SURVIVE conducted by Nobel prize winner Reinhard Selten and Michael Schreckenberg). Optimal recommendations to reach the user equilibrium follow directly from the derived balance equation (95) for decision changes based on empirical transition and compliance probabilities. The quantification of the transition probabilities requires a novel stochastic description of the decision behavior, which is not just driven by the potential (gains in) payoffs, in contrast to intuition and established models. To understand these findings, one has to take into account reinforcement learning, which can also explain the emergence of individual response patterns (see Sec. 5).

Obviously, it requires both, theoretical and experimental efforts to get ahead in decision theory. In a decade from now, the microscopic theory of human interactions will probably have been developed to a degree that allows one to systematically derive social patterns and economic dynamics on this ground. This will not only yield a deeper understanding of socio-economic systems, but also help to more efficiently distribute scarce resources such as road capacities, time, space, money, energy, goods, or our natural environment. One day, similar guidance strategies as the ones suggested above may help politicians and managers to stabilize economic markets, to increase average *and* individual profits, and to decrease the unemployment rate.

Acknowledgments. This study was partially supported by the ALTANA-Quandt foundation. The author wants to thank Prof. Aruka, Prof. Selten, and Prof. Schreckenberg for their invitations and fruitful discussions, Prof. Kondor and Dr. Schadschneider for inspiring comments, Tilo Grigat for preparing some of the illustrations, Martin Schönhof and Daniel Kern for their help in setting

up and carrying out the decision experiments, and the test persons for their patience and ambitious playing until the end of our experiments. Hints regarding manuscript-related references are very much appreciated. Last but not least the author has very much appreciated the warm hospitality and the challenging intellectual atmosphere at the Santa Fe Institute, where this paper has been contributed for discussion by the Social Scaling Working Group in August 2003.

References

1. D. Helbing, *Traffic and related self-driven many-particle systems*, Reviews of Modern Physics **73**, 1067-1141 (2001).
2. J. H. Hagel and A. E. Roth (Eds.), *The Handbook of Experimental Economics* (Princeton University, Princeton, NJ, 1995).
3. A. Shleifer, *Inefficient Markets: An Introduction to Behavioral Finance* (Clarendon Lectures, Oxford University, Oxford, 2000).
4. W. B. Arthur, *Inductive reasoning and bounded rationality*, American Economic Review **84**, 406-411 (1994).
5. D. Challet and Y.-C. Zhang, *Emergence of cooperation and organization in an evolutionary game*, Physica A **246**, 407ff (1997).
6. D. Challet and Y.-C. Zhang, *On the minority game: Analytical and numerical studies*, Physica A **256**, 514-532 (1998).
7. D. Challet, M. Marsili, and Y.-C. Zhang, *Modeling market mechanism with minority game* Physica A **276**, 284-315 (2000).
8. H. C. Rachlin, *Behavior and Learning* (Freeman, San Francisco, 1976).
9. H. C. Rachlin and W. M. Baum, *Effects of alternative reinforcement: Does the source matter?*, Journal of the Experimental Analysis of Behavior **18**, 231-241 (1972).
10. S. R. Schroeder and J. G. Holland, *Reinforcement of eye movement with concurrent schedules*, Journal of the Experimental Analysis of Behavior **12**, 897-903 (1969).
11. G. T. Fechner, *Elemente der Psychophysik* (1860).
12. T. A. Domencich and D. M. McFadden, *Urban Travel Demand. A Behavioral Analysis*, pp. 61-69, (North-Holland, Amsterdam, 1975).
13. J. de D. Ortúzar and L. G. Willumsen, *Modelling Transport*, Chap. 7: Discrete-Choice Models (Wiley, Chichester, 1990).
14. M. Ben-Akiva, D. M. McFadden *et al.*, *Extended framework for modeling choice behavior*, Marketing Letters **10**, 187-203 (1999).
15. F. Reif, *Fundamentals of Statistical and Thermal Physics*, pp. 202ff, 229ff (McGraw-Hill, Singapore, 1965).
16. W. G. V. Rosser, *An Introduction to Statistical Physics*, pp. 108f. (Horwood, Chichester, 1982).
17. H. Haken, *Information and Self-Organization* (Springer, Berlin, 1988).
18. D. Helbing, *Stochastische Methoden, nichtlineare Dynamik und quantitative Modelle sozialer Prozesse* (Shaker, Aachen, 1996).
19. D. Helbing, *Quantitative Sociodynamics* (and references therein) (Kluwer Academic, Dordrecht, 1995).
20. F. Heider, *Attitudes and cognitive organization*, Journal of Psychology **21**, 107-112 (1946).
21. F. Heider, *The Psychology of Interpersonal Relations* (Wiley, New York, 1958).

22. D. Cartwright and F. Harary, *Structural balance: A generalization of Heider's theory*, *Psychological Review* **63**, 277-293 (1956).
23. C. E. Osgood and P. H. Tannenbaum, *The principle of congruity in the prediction of attitude change*, *Psychological Review* **62**, 42-55 (1955).
24. L. Festinger, *A Theory of Cognitive Dissonance* (Row & Peterson, Evanston, IL, 1957).
25. S. S. Brehm, *The Application of Social Psychology to Clinical Practice* (Wiley, New York, 1976).
26. J. Binder, G. Haag, and M. Koller, *Modelling and simulation of migration, regional employment development and regional gross wage payment in Germany: The bottom-up approach*, in *Regional Economies in Transition* (Research Report 02:1, University of Trollhättan/Uddevalla, 2002).
27. H. Feger (Ed.), *Studien zur intraindividuellen Konfliktforschung* (Huber, Bern, 1977).
28. H. Feger, *Konflikterleben und Konfliktverhalten* (Huber, Bern, 1978).
29. A. Babloyantz and A. Destexhe, *Strange attractors in the human cortex*, in *Temporal Disorder in Human Oscillatory Systems*, L. Rensing, U. van der Heiden, and M. C. Mackey (Eds.) (Springer, Heidelberg, 1987).
30. A. Babloyantz, C. Nicolis, and M. Salazar, *Evidence of chaotic dynamics of brain activity during the sleep cycle*, *Physics Letters A* **111**, 152 (1985).
31. C. E. Osgood, G. J. Suci, and P. H. Tannenbaum, *The Measurement of Meaning* (University of Illinois Press, Urbana, 1957).
32. P. H. Douglas, *The Theory of Wages*, pp. 132-135 (Macmillan, New York, 1934).
33. W. Nicholson, *Microeconomic Theory*, pp. 90ff, 111ff (Dryden Press, Fort Worth, 5th edition, 1992).
34. M. Ben-Akiva, J. Bottom, and M. S. Ramming, *Route guidance and information systems*, *Int. J. Syst. Contr. Engin.* **215**, 317-324 (2001).
35. B. Libet, C. A. Gleason, E. W. Wright, and D. K. Pearl, *Time of conscious intention to act in relation to onset of cerebral activity (readiness-potential)*, *Brain* **106**, 623-642 (1983).
36. P. Haggard and M. Eimer, *On the relation between brain potentials and the awareness of voluntary movements*, *Experimental Brain Research* **126**, 128-133 (1999).
37. J. H. Harvey, *Attribution of freedom*, in *New Directions in Attribution Research*, Chap. 4, J. H. Harvey, W. J. Ickes, and R. F. Kidd (Eds.) (Wiley, New York, 1976).
38. I. D. Steiner, *Perceived freedom*, in *Advances in Experimental Social Psychology*, L. Berkowitz (Ed.) (Academic Press, New York, 1970).
39. J. W. Brehm, *Responses to Loss of Freedom: A Theory of Psychological Reactance*, (General Learning Press, Morristown, NJ, 1972).
40. J. W. Brehm, *A Theory of Psychological Reactance* (Academic Press, New York, 1966).
41. C. B. Wortman and J. W. Brehm, *Responses to uncontrollable outcomes: An integration of reactance theory and the learned helplessness model*, in *Advances in Experimental Social Psychology*, pp. 277-336, L. Berkowitz (Ed.) (Academic Press, New York, 1975).
42. W. Weidlich and G. Haag, *Concepts and Models of a Quantitative Sociology. The Dynamics of Interacting Populations* (Springer, Berlin, 1983).
43. W. Weidlich, *Physics and social science—The approach of synergetics*, *Physics Reports* **204**, 1-163 (1991).
44. W. Weidlich, *Sociodynamics. A Systematic Approach to Mathematical Modelling in the Social Sciences*, (Harwood Academic, Amsterdam, 2000).

45. D. Helbing, *Microscopic foundation of stochastic game dynamical equations*, in *Game Theory, Experience, Rationality*, pp. 211-224, W. Leinfellner and E. Köhler (Eds.) (Kluwer Academic, Dordrecht, 1998).
46. D. Helbing, *A mathematical model for behavioral changes by pair interactions and its relation to game theory*, *Angewandte Sozialforschung* **18**(3), 117-132 (1994).
47. D. Helbing, *Stochastic and Boltzmann-like models for behavioral changes, and their relation to game theory*, *Physica A* **193**, 241-258 (1993).
48. D. Helbing, *Interrelations between stochastic equations for systems with pair interactions*, *Physica A* **181**, 29-52 (1992).
49. D. Helbing, *A mathematical model for the behavior of individuals in a social field*, *Journal of Mathematical Sociology* **19**(3), 189-219, (1994).
50. R. S. Burt, *Towards a Structural Theory of Action. Network Models of Social Structure, Perception, and Action*, (Academic Press, New York, 1982).
51. N. Braun, *Socially Embedded Exchange* (Lang, Frankfurt/Main, 1993).
52. A. Krawiecki, J. A. Holyst, and D. Helbing, *Volatility clustering and scaling for financial time series due to attractor bubbling*, submitted.
53. D. Helbing, I. Farkas, and T. Vicsek, *Simulating dynamical features of escape panic*, *Nature* **407**, 487-490 (2000).
54. M. Fishbein and I. Ajzen, *Belief, Attitude, Intention and Behavior: An Introduction to Theory and Research*, (Addison-Wesley, Reading, MA, 1975).
55. N. H. Anderson, *Group performance in an anagram task*, *Journal of Social Psychology* **55**, 67-75 (1961).
56. H. H. Kelley and J. W. Thibaut, *Group problem solving*, in *The Handbook of Social Psychology*, Vol. 4, G. Lindzey and E. Aronson (Eds.) (Addison-Wesley, Reading, MA, 1969).
57. P. R. Laughlin, N. L. Kerr, J. H. Davis, H. M. Halff, and K. A. Marciniak, *Group size, member ability, and social decision schemes on an intellectual task*, *Journal of Personality and Social Psychology* **31**, 522-535 (1975).
58. R. Pearl, *Studies in Human Biology* (Williams & Wilkins, Baltimore, 1924).
59. P. F. Verhulst, *Nouveaux Mémoires de l'Académie Royale des Sciences et des Belles-Lettres de Bruxelles* **18**, 1ff (1845).
60. D. J. Bartholomew, *Stochastic Models for Social Processes* (Wiley, London, 1967).
61. E. W. Montroll and W. W. Badger, *Introduction to Quantitative Aspects of Social Phenomena* (Gordon and Breach, New York, 1974).
62. R. L. Hamblin, R. B. Jacobsen, and J. L. L. Miller, *A Mathematical Theory of Social Change* (New York, 1973).
63. M. Olinick, *An Introduction to Mathematical Models in the Social and Life Sciences*, pp. 59-65, (Addison-Wesley, Reading, MA, 1978).
64. E. Ravenstein, *The birthplaces of the people and the laws of migration*, *The Geographical Magazine* **III**, 173-177, 201-206, 229-233 (1876).
65. G. K. Zipf, *The P1P2/D hypothesis on the intercity movement of persons*, *American Sociological Review* **11**, 677-686 (1946).
66. W. Weidlich and G. Haag (Eds.), *Interregional Migration* (Springer, Berlin, 1988).
67. G. Haag, *Dynamic Decision Theory. Applications to Urban and Regional Topics* (Kluwer Academic, Dordrecht, 1989).
68. D. Helbing, *Boltzmann-like and Boltzmann-Fokker-Planck equations as a foundation of behavioral models*, *Physica A* **196**, 546-573 (1993).
69. K. Lewin, *Field Theory in Social Science* (Harper and Brothers, New York, 1951).
70. D. Helbing, *A mathematical model for the behavior of pedestrians*, *Behavioral Science* **36**, 298-310 (1991).

71. A. Nowak, J. Szamrej, and B. Latané, *From private attitude to public opinion: A dynamic theory of social impact*, Psychological Review **97**, 362-376 (1990).
72. M. Lewenstein, A. Nowak, and B. Latané, *Statistical mechanics of social impact*, Physical Review A **45**, 763-776 (1992).
73. R. Vallacher and A. Nowak (Eds.), *Dynamic Systems in Social Psychology* (Academic, New York, 1994).
74. K. Kacperski and J. A. Holyst, *Phase transitions and hysteresis in a cellular automata-based model of opinion formation*, Journal of Statistical Physics **84**, 169-189 (1996).
75. D. Helbing, *Verkehrsdynamik. Neue physikalische Modellierungskonzepte* (Springer, Berlin, 1997).
76. D. Helbing and B. Tilch, *Generalized force model of traffic dynamics.*, Physical Review E **58**, 133-138 (1998).
77. M. Treiber, A. Hennecke, and D. Helbing, *Congested traffic states in empirical observations and microscopic simulations*, Physical Review E **62**, 1805-1824 (2000).
78. D. Helbing and P. Molnár, *Social force model for pedestrian dynamics*, Physical Review E **51**, 4282-4286 (1995).
79. D. Helbing, I. Farkas, and T. Vicsek, *Freezing by heating in a driven mesoscopic system*, Physical Review Letters **84**, 1240-1243 (2000).
80. D. Helbing, *Boltzmann-like and force models for behavioral changes*, in *Operations Research '93*, pp. 251-254, A. Bachem, U. Derigs, M. Jünger, and R. Schrader (Eds.) (Physica, Heidelberg, 1994).
81. J. Hofbauer, P. Schuster, and K. Sigmund, *A note on evolutionarily stable strategies and game dynamics*, Journal of Theoretical Biology **81**, 609-612 (1979).
82. P. Taylor and L. Jonker, *Evolutionarily stable strategies and game dynamics*, Mathematical Biosciences **40**, 145-156 (1978).
83. E. C. Zeeman, *Population dynamics from game theory*, in *Global Theory of Dynamical Systems* (1980).
84. J. Hofbauer and K. Sigmund, *The Theory of Evolution and Dynamical Systems* (Cambridge University Press, Cambridge, 1988).
85. M. Eigen, *The selforganization of matter and the evolution of biological macromolecules*, Naturwissenschaften **58**, 465 (1971).
86. R. A. Fisher, *The Genetical Theory of Natural Selection* (Oxford University Press, Oxford, 1930).
87. D. Helbing, *A mathematical model for behavioral changes by pair interactions*, in *Economic Evolution and Demographic Change. Formal Models in Social Sciences*, pp. 330-348, G. Haag, U. Mueller, and K. G. Troitzsch (Eds.) (Springer, Berlin, 1992).
88. K. H. Schlag, *Why imitate, and if so, how? A bounded rational approach to multi-armed bandits*, Discussion Paper No. B-361 (Department of Economics, University of Bonn).
89. A. J. Lotka, *Analytical note on certain rhythmic relations in organic systems*, Proceedings of the National Academy of Sciences of the United States of America **6**, 410 (1920).
90. A. J. Lotka, *Elements of Mathematical Biology* (Dover, New York, 1956).
91. V. Volterra, *Leçons sur la Théorie Mathématique de la Lutte pour la Vie* (Gauthier-Villars, Paris, 1931).
92. N. S. Goel, S. C. Maitra, and E. W. Montroll, *On the Volterra and other nonlinear models of interacting populations*, Reviews of Modern Physics **43**(2), 231-276 (1971).

93. Th. G. Hallam, *Community dynamics in a homogeneous environment*, in *Mathematical Ecology*, T. G. Hallam and S. A. Levin (Eds.) (Springer, Berlin, 1986).
94. M. Peschel and W. Mende, *The Predator-Prey Model* (Springer, Wien, 1986).
95. D. Helbing, *A mathematical model for attitude formation by pair interactions*, *Behavioral Science* **37**, 190-214 (1992).
96. D. Helbing, *A stochastic behavioral model and a 'microscopic' foundation of evolutionary game theory*, *Theory and Decision* **40**, 149-179 (1996).
97. W. B. Arthur, *Competing technologies, increasing returns, and lock-in by historical events*, *The Economic Journal* **99**, 116-131 (1989).
98. M. Schreckenberg and R. Selten (Eds.), *Human Behaviour and Traffic Networks* (Springer, Berlin, 2002), to appear.
99. W. Barfield and T. Dingus, *Human Factors in Intelligent Transportation Systems* (Erlbaum, Mahwah, NJ, 1998).
100. J. Wahle, A. Bazzan, F. Klügl, and M. Schreckenberg, *Decision dynamics in a traffic scenario*, *Physica A* **287**, 669-681 (2000).
101. Articles in *Route Guidance and Driver Information*, IEE Conference Publications, Vol. **472** (IEE, London, 2000).
102. M. Ben-Akiva, A. de Palma, and I. Kaysi, *Dynamic network models and driver information systems*, *Transportation Research A* **25**, 251-266 (1991).
103. H. S. Mahmassani and R. Jayakrishnan, *System performance and user response under real-time information in a congested traffic corridor*, *Transportation Research A* **25**, 293-307 (1991).
104. R. Arnott, A. de Palma, and R. Lindsey, *Does providing information to drivers reduce traffic congestion?*, *Transportation Research A* **25**, 309-318 (1991).
105. J. Adler, and V. Blue, *Towards the design of intelligent traveler information systems*, *Transportation Research C* **6**, 157-172 (1998).
106. H. S. Mahmassani and R. C. Jou, *Transferring insights into commuter behavior dynamics from laboratory experiments to field surveys*, *Transportation Research A* **34**, 243-260 (2000).
107. P. Bonsall, P. Firmin, M. Anderson, I. Palmer, and P. Balmforth, *Validating the results of a route choice simulator* *Transportation Research C* **5**, 371-387 (1997).
108. Y. Iida, T. Akiyama, and T. Uchida, *Experimental analysis of dynamic route choice behavior*, *Transportation Research B* **26**, 17-32 (1992).
109. P. S.-T. Chen, K. K. Srinivasan, and H. S. Mahmassani, *Effect of information quality on compliance behavior of commuters under real-time traffic information*, *Transportation Research Record* **1676**, 53-60 (1999).
110. R. D. Kühne, K. Langbein-Euchner, M. Hilliges, and N. Koch, *Evaluation of compliance rates and travel time calculation for automatic alternative route guidance systems on freeways.*, *Transportation Research Record* **1554**, 153-161 (1996).
111. R. Hall, *Route choice and advanced traveler information systems on a capacitated and dynamic network*, *Transportation Research C* **4**, 289-306 (1996).
112. A. Khattak, A. Polydoropoulou, and M. Ben-Akiva, *Modeling revealed and stated pretrip travel response to advanced traveler information systems*, *Transportation Research Record* **1537**, 46-54 (1996).
113. M. Schreckenberg, R. Selten, T. Chamura, T. Pitz, and J. Wahle, *Experiments on day-to-day route choice* (and references therein), e-print www.trafficforum.org/01080701, submitted to Cooper@tive Tr@nsport@tion Dyn@mics (2001).
114. H. N. Koutsopoulos, A. Polydoropoulou, and M. Ben-Akiva, *Travel simulators for data collection on driver behavior in the presence of information*, *Transportation Research C* **3**, 143-159 (1995).

115. H. S. Mahmassani, and D.-G. Stephan, *Experimental investigation of route and departure time choice dynamics of urban commuters*. Transportation Research Records **1203**, 69-84 (1988).
116. P. Bonsall, *The influence of route guidance advice on route choice in urban networks*, Transportation **19**, 1-23 (1992).
117. D. Helbing, M. Schönhof, and D. Kern, *Volatile decision dynamics: Experiments, stochastic description, intermittency control, and traffic optimization*, New Journal of Physics **4**, 33.1-33.16 (2002).
118. D. Helbing, *A section-based queueing-theoretical traffic model for congestion and travel time analysis*, submitted to J. Phys. A: Math. Gen. (2003).
119. D. Fudenberg and D. Levine, *The Theory of Learning in Games* (MIT Press, Cambridge, MA, 1998).
120. M. W. Macy and A. Flache, *Learning dynamics in social dilemmas*, Proceedings of the National Academy of Sciences USA **99**, Suppl. 3, 7229-7236 (2002).
121. R. N. Mantegna, and H. E. Stanley, *Introduction to Econophysics: Correlations and Complexity in Finance* (Cambridge University, Cambridge, England, 1999).
122. S. Ghashghaie, W. Breymann, J. Peinke, P. Talkner, and Y. Dodge, *Turbulent cascades in foreign exchange markets*, Nature **381**, 767-770 (1996).
123. T. Lux and M. Marchesi, *Scaling and criticality in a stochastic multi-agent model of a financial market*, Nature **397**, 498-500 (1999).
124. J. Wahle, A. L. C. Bazzan, F. Klügl, and M. Schreckenberg, *Anticipatory traffic forecast using multi-agent techniques*, in *Traffic and Granular Flow '99*, pp. 87-92, D. Helbing, H. J. Herrmann, M. Schreckenberg, and D. E. Wolf (Eds.) (Springer, Berlin, 2000).
125. M. Kraan, H. S. Mahmassani, and N. Huynh, *Traveler Responses to Advanced Traveler Information Systems for Shopping Trips: Interactive Survey Approach*, Transportation Research Record **1725**, 116 (2000).
126. K. K. Srinivasan and H. S. Mahmassani, *Modeling Inertia and Compliance Mechanisms in Route Choice Behavior Under Real-Time Information*, Transportation Research Record **1725**, 45-53 (2000).
127. M. Ben-Akiva and S. R. Lerman, *Discrete Choice Analysis: Theory and Application to Travel Demand* (MIT Press, Cambridge, MA, 1997).
128. S. Nakayama and R. Kitamura, *Route Choice Model with Inductive Learning*, Transportation Research Record **1725**, 63-70 (2000).
129. Y.-W. Cheung and D. Friedman, *Individual learning in normal form games: Some laboratory results*, Games and Economic Behavior **19**(1), 46-76 (1997).
130. I. Erev and A. E. Roth, *Predicting how people play games: Reinforcement learning in experimental games with unique, mixed strategy equilibria*, American Economic Review **88**(4), 848-881 (1998).
131. J. Nachabar, *Prediction, optimization, and learning in repeated games*, Econometrica **65**, 275-309 (1997).
132. J. B. van Huyck, R. C. Battlio, and R. O. Beil, *Tacit coordination games, strategic uncertainty, and coordination failure*, American Economic Review **80**(1), 234-252 (1990).
133. J. B. van Huyck, J. P. Cook, and R. C. Battlio, *Selection dynamics, asymptotic stability, and adaptive behavior*, Journal of Political Economy **102**(5), 975-1005 (1994).